

## State Minimization (Ch. 2.5)

Why?

### Algorithm

- Remove states that are not reachable
- Identify states that are indistinguishable  
These states form a new state

**Definition** Two states  $p$  and  $q$  are indistinguishable if for all  $w \in \Sigma^*$

$$\begin{aligned}\delta^*(q, w) \in F &\Rightarrow \delta^*(p, w) \in F \\ \delta^*(p, w) \notin F &\Rightarrow \delta^*(q, w) \notin F\end{aligned}$$

**Definition** Two states  $p$  and  $q$  are distinguishable if  $\exists w \in \Sigma^*$  s.t.

$$\begin{aligned}\delta^*(q, w) \in F &\Rightarrow \delta^*(p, w) \notin F \text{ OR} \\ \delta^*(q, w) \notin F &\Rightarrow \delta^*(p, w) \in F\end{aligned}$$

### Algorithm for Minimizing Number of States in DFA

1. Remove states that are not reachable.
2. Group all nonfinal states together as indistinguishable
3. Group all final states together as indistinguishable
4. Repeat til no more states are distinguishable
  - (a) Apply symbol to a group and split group if states are distinguishable

Example:

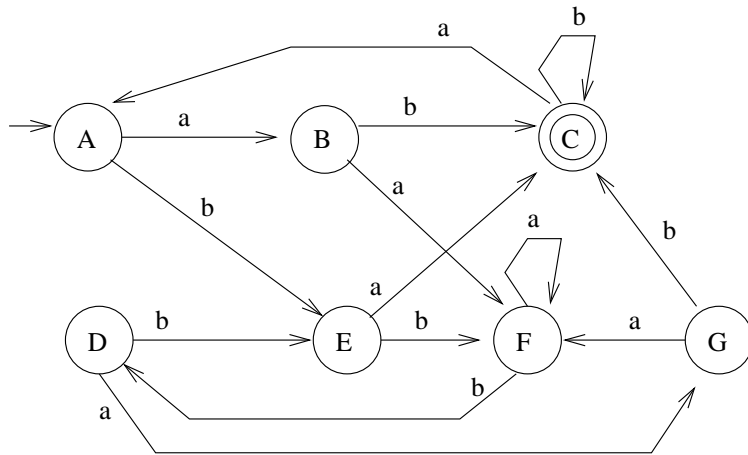

**Example:**

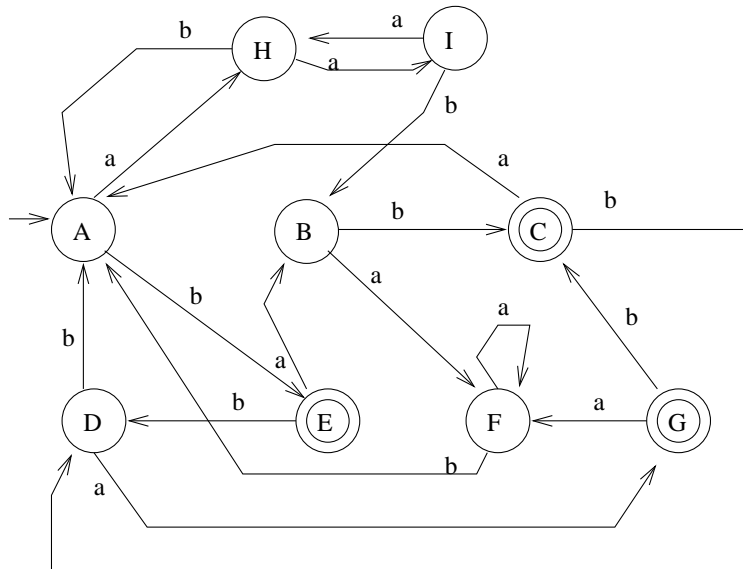

**Analysis of Algorithms: (Ch 2.6)**

1. Given DFA  $M$  and string  $w$ , is  $w \in L(M)$ ?
2. Given NFA  $M$  and string  $w$ , is  $w \in L(M)$ ?
3. Given an NFA  $M_1$ , create a DFA  $M_2$  s.t.  $L(M_1) = L(M_2)$
4. Given a DFA  $M_1$ , create a minimal state DFA  $M_2$  s.t.  $L(M_1) = L(M_2)$
5. Given a NFA  $M_1$ , create a minimal state DFA  $M_2$  s.t.  $L(M_1) = L(M_2)$