

Query Optimization for XML

By Jason Mchugh, Jennifer Widom

Dazhi Wang
CPS296.1
Topics in Database Systems

Outline

- Basics for Lore system
- Motivation
- Query Execution Engine
 - ◆ Logical Query Plans
 - ◆ Statistics and Cost Models
 - ◆ Physical Plan Enumeration
- Performance Results

Introduction

- Lore System
 - ◆ DBMS for semistructured data
 - ◆ Data model: OEM
- What complicate query optimization for XML
 - ◆ Variety of indexes and traversal techniques increases the search space
 - ◆ How to choose appropriate set of statistics for graph-based data and how to compute and store them efficiently

OEM model for XML

- OEM model: a labeled directed graph
 - ◆ Data in OEM is schema-less and self-describing
 - ◆ Atomic objects: vertices with data, no outgoing edge
 - ◆ Complex objects: vertices with outgoing edge
 - ◆ Labeled edges: express property relationships
 - ◆ Names: special labels recognizing single objects
- Correspondence between OEM and XML
 - ◆ OEM's objects: elements in XML
 - ◆ Subobject relationship in OEM: element nesting in XML
 - ◆ Difference: subelements in XML are inherently ordered; XML elements may include a list of attribute-value pairs

OEM model for XML (cont.)

```
<Member Project = "&5 &6">  
<Name>Jones</Name>  
<Office>  
  <Building>  
    Gates  
  </Building>  
  <Room>252</Room>  
</Office>  
<Age> 46 </Age>  
</Member>
```

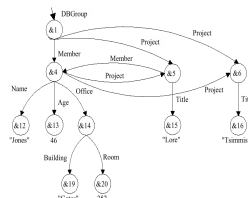

OEM model for XML (cont.)

- Simple Path Expression
 - ◆ Represents a single-step navigation in the database. Has the form $x.l y$
 - ◆ e.g. $DBGroup.Project x$
- Path Expression
 - ◆ Ordered list of simple path expressions
 - ◆ e.g. $DBGroup.Member x, x.Age y$

Lore's Query Language: *Lorel*

- Lorel is an extension of OQL, which is an SQL-like declarative language.
- Example:

```

      Select x
      From DBGroup.Member x
      Where exists y in x.Age: y<30
      
```
- Operands:
 - ◆ constants, named objects, variables
- Operations:
 - ◆ Selection, set, quantification, aggregation
- Path expression can appear in *select*, *from* or *where* clause

Lore Query Processing

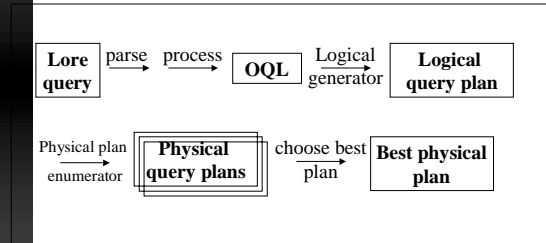

Lore Indexes

- *Vindex*
 - ◆ Find atomic objects given label and predicates
- *Lindex*
 - ◆ Find parents given object and label
- *Bindex*
 - ◆ Find parent-child pairs given an edge label
- *Pindex*
 - ◆ Find the object given a path

Path to a node is as important as the node's value

Motivation

- The optimal query plan depends on
 - ◆ *Values* in the database
 - ◆ *Shape* of the graph model



Optimization is both important and difficult

Motivation (cont.)

e.g.: Select x From A.B x where exists y in x.C: y=5

Strategy: *top-down, bottom-up, hybrid*

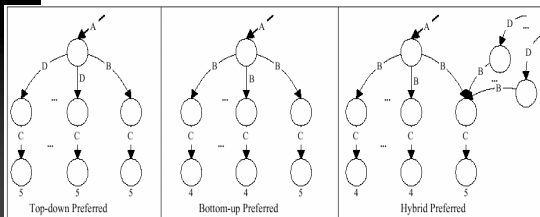

Query Execution Engine

- *Variable binding:* assign an object to a variable in the query
- *Evaluation:* a list of all variables in the plan along with the object bound to each variable
- The goal: iteratively generate complete evaluations to produce query results

Logical Query Plans

- To execute:
 - Select x From DBGroup.Member x Where exists y in x.Age: y<30
 - ◆ Top-down approach: handle *From* clause first
 - ◆ Bottom-up approach: handle *where* clause first
- For the *where* clause:
 - ◆ Break it into: (a) find all *Age* subobjects of *x*
(b) test their values
 - ◆ Top-down approach: first (a) then (b)
 - ◆ Bottom-up approach: first find (b) using **Vindex**, then (a) using **Lindex**

Logical Query Plans (cont.)

- Solution:
 - ◆ break the query into independent components, where execution order not fixed
 - ◆ *Rotation points*: where the components meet
 - ◆ Build a tree of logical operators based on independent components
 - ◆ *Discover(x,"B", y)*: bind *x* and *y*
 - ◆ *Chain(r,l)*: link left & right subplan
 - ◆ *Glue(r,l)*: represent a rotation point
 - ◆ Each logical operator constructs its optimal physical plan

Logical Query Plans (cont.)

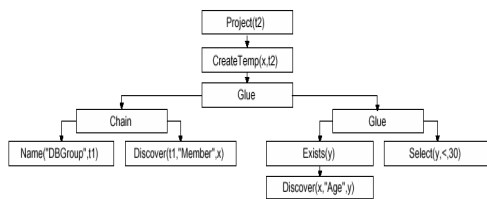

Figure 4: A complete logical query plan

A complete logical query plan for the previous example

Physical Query Plan

- Physical query plan operators are *iterators*
 - ◆ Request a tuple at a time from its children
 - ◆ Performs some operation
 - ◆ Returns the result to the parent
 - ◆ The “tuples” are *evaluations*
- Six basic traversal operators:
 - ◆ *Scan(x, l, y)*, *Lindex(x, l, y)*, *Pindex(Pathexpression, x)*, *Bindex(l, x, y)*, *Name(x, n)*, *Vindex(Op, Value, l, x)*
- Other operators:
 - ◆ projection, selection, aggregation, set, etc.

Traversal Operators

- **Scan(x,l,y)**: place into *y* all subobjects of *x* connected via *l*.
- **Lindex(x,l,y)**: place into *x* all parents of *y* connected via *l*.
- **Pindex(pathexp, x)**:
- **Bindex(l,x,y)**: all *x-y* pairs connected via *l*
- **Name(x,n)**: verify if *x* is the named obj *n*.
- **Vindex(Op,value,l,x)**: place into *x* all atomic objects satisfying “Op value” and having incoming label *l*.

Physical Query Plan (cont.)

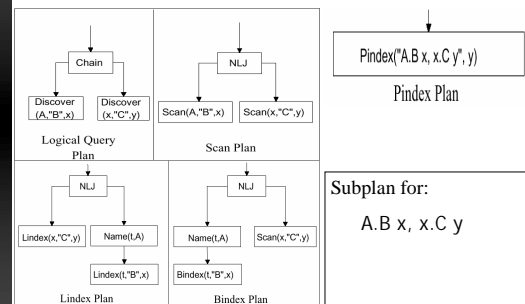

Statistics and Cost Model

- To estimate the execution cost for a given physical query plan

Statistics

- Need to consult:
 - size & shape of the database
 - range of values
- Tradeoff between time & space and accuracy

Statistics (cont.)

- For every label subpath p of length $\leq k$
 - ◆ \forall atomic type, #atomic objs (of type) reachable
 - ◆ \forall atomic type, min&max values reachable
 - ◆ Total # of instances of path p , $|p|$
 - ◆ Total # of distinct objs reachable, $|p|_d$
 - ◆ Total # of l-labeled sub-objects reachable, $|p|_l$
 - ◆ Total # of incoming l-labeled edges, $|p|^l$

Statistics (cont.)

- Example: evaluate $A.B \ x, \ x.C \ y$
 - ◆ Top-down: need to estimate # C subobjects
 - ◆ *fan-out*: $|p| * (|p|_l / |p|_d)$
 - ◆ Bottom-up: need to estimate # parents via a B edge for all C's
 - ◆ *fan-in*: $|p| * (|p|^l / |p|_d)$
- Accurate for $(k+1)$ path, estimate $(k+2)$ path using $(k+1)$ path

Cost Model

- Execution cost:
 - ◆ I/O cost= predicted # of objects fetched
 - ◆ Rough estimation, due to lack of clustering knowledge in Lore
 - ◆ CPU cost – secondary to I/O
 - ◆ Expected # of evaluations
- Node-cost = children_cost + self_cost
- The cost model is Simplistic

Plan Enumeration

- Large search space of physical query plan
 - ◆ Path of length $n \Leftrightarrow n$ -way join
 - ◆ Interrelated path expressions
 - ◆ Set operation, Sub-query, aggregation, etc.
- Solution: Greedy approach
 - ◆ A logical plan node makes a locally optimal decision based on bound variables passed from its parents
 - ◆ May make optimal physical subplan many times
 - ◆ Problem: still explore exponentially large # of plan

Aggressive Pruning

- Join 2 simple paths iff sharing common variable
- *Pindex* operator only starts from a named object, & no variable except the last is used elsewhere
- *Select* clause always executes last
- Separate *From* and *Where* clauses
- No reorder on multiple independent paths

n: number of simple path expressions	n=3	n=5	n=7
All possible plans/Lore's search space	1458 / 48	2,361,960 / 228	8,035,387,920 / 948

Table 1: Analysis of Search Space Size

Producing physical plans

- Each logical plan node creates optimal local physical plan given a set of bound variables
- Need to track for a variable:
 - bound or not
 - Which operator bound it
 - All other operators that use it
 - Whether it is stored in a temporary result

Example: $Discover(x.Age\ y)$

- x is bound: *scan* operator may be optimal
- y is bound: *Lindex* operator may be optimal

Producing physical plans (Example)

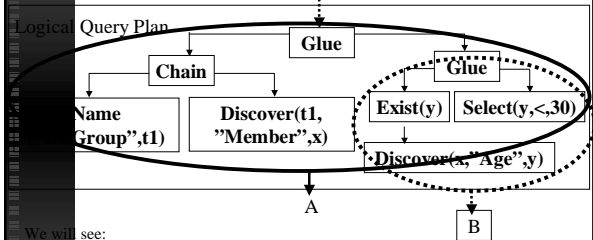

We will see:

- A – Left then Right
- A – Right then Left → B – Left then Right
- A – Right then Left → B – Right then Left
- Select x
- From $DBGroup.Member\ x$
- Where exists y in $x.Age: y < 30$

Producing physical plans (Example)

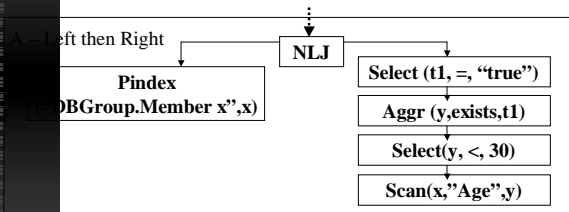

Producing physical plans (Example)

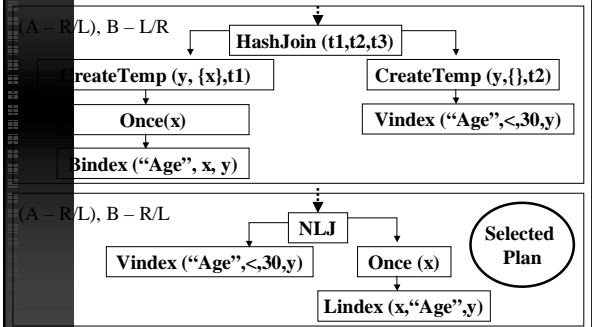

Producing physical plans (Example)

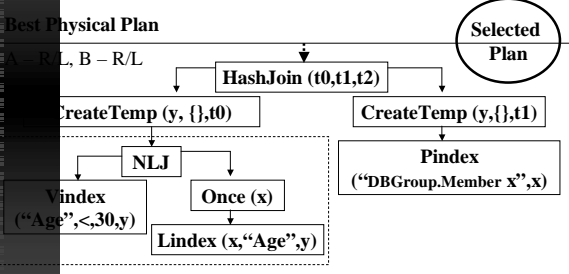

Performance Results

- Experiment over a 5 MB database on movies
- Indexes size: 8.1 MB
- 62,256 nodes
- 130,402 edges

Avg. optimization time per query ~ 1/2 sec.

Performance Results (cont.)

Plan #	1*	2	3	4	5	6	7	8	9	10	11
Exec. Time (sec.)	0.36	1.78	2.02	14.44	61.82	67.24	74.09	94.15	250.61	397.18	423.34
Estimated I/O	1975	3944	3944	9853	31918	31918	11823	37827	17742	17733	23855

Table 2: Query execution times
 "Select DB.Movie.Title"

Rank	Time	Description
1*	0.3307	Bottom-up
2	0.3768	<i>Bindex, Select then Lindex</i>
7	3.3384	Top-down
24	458.58	Full <i>Bindex</i>

movies with Genre subject having value "Comedy"

Performance Results (cont.)

Rank	Time	Description
1	0.33	Bottom-up
2*	3.68	Top-down
3	6.95	Hybrid with <i>Pindex</i>
4	7.01	Hybrid with pointer-chasing
5	23.13	<i>Bindex</i> and <i>Vindex</i> then <i>Lindex</i>

a query with two existentially quantified variables

Summary

- Logical Plan
 - New Indexes
 - Physical Plans
 - New Statistics
- } *Aggressive Pruning*
- } **Best physical plans**