

DNA Reaction Networks Fueled by Strand Displacement

Hieu Bui

Edited by John Reif

Outline

- **Yurke-Tuberfield's DNA Tweezers:**
 - the invention of toe-hold mediated strand displacement
- **Yurke: Catalytic Tweezers**
- **Quan-Winfree's Seesaw Gates**
- **Bernard Yurke's DNA Catalytic Reactions**
- **Zhang's DNA Reaction Networks**
- **Zhang's Allosteric DNA Catalytic Reactions**

Strand Displacement

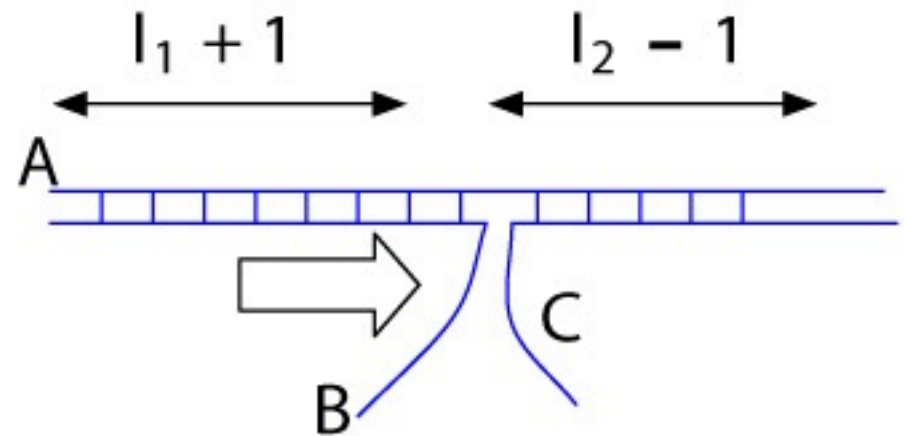
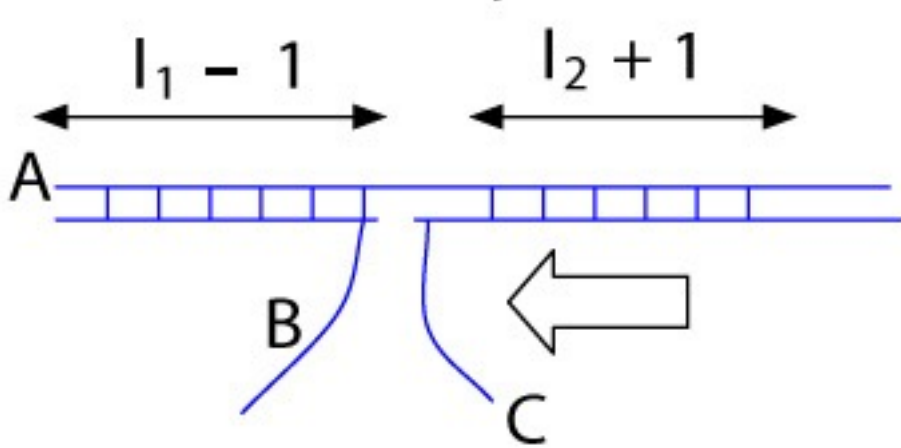
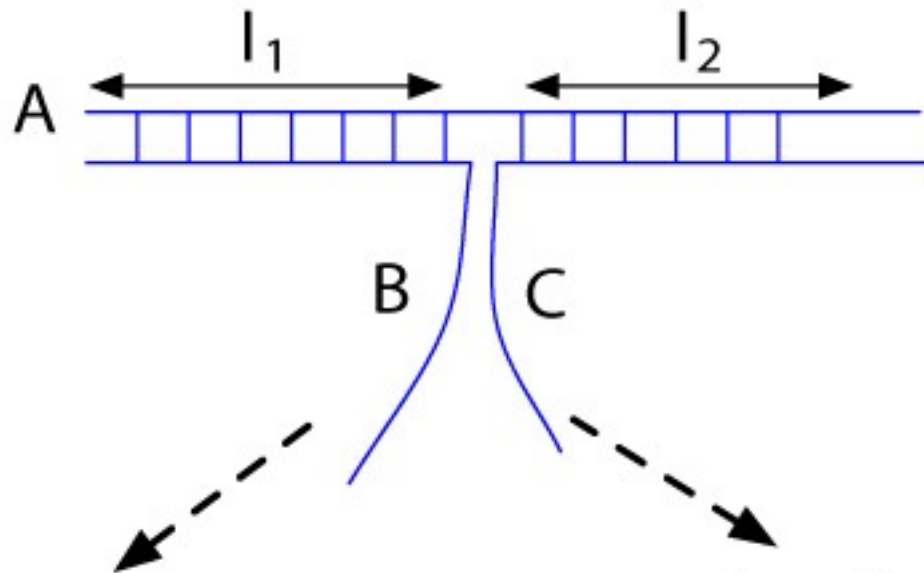

Toehold mediated strand displacement



Example of Toehold mediated strand displacement

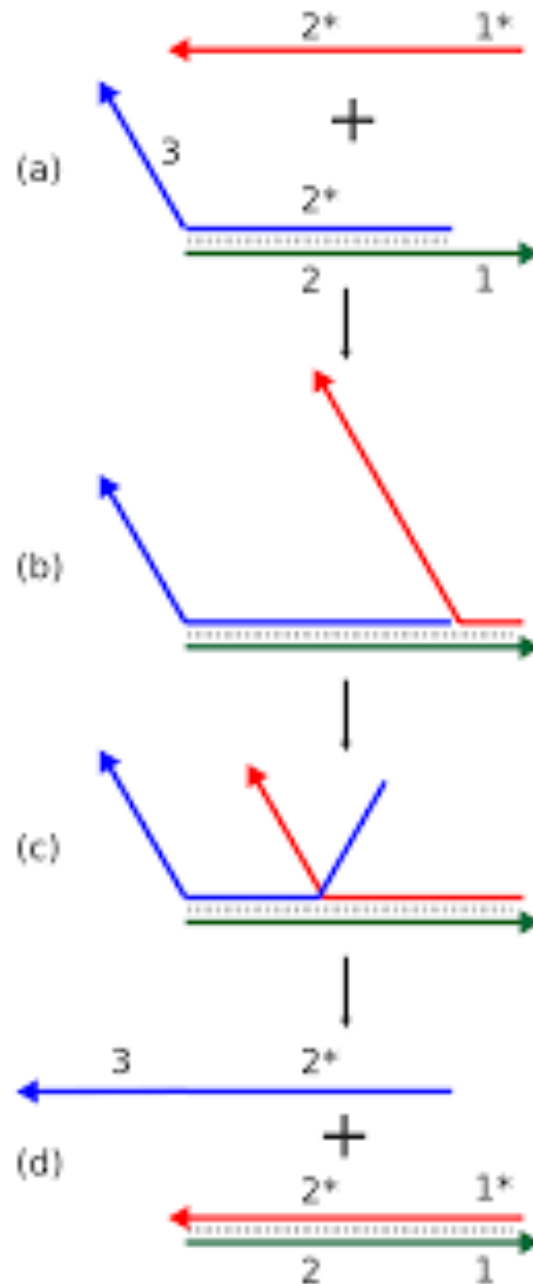

Details of Toehold mediated strand displacement

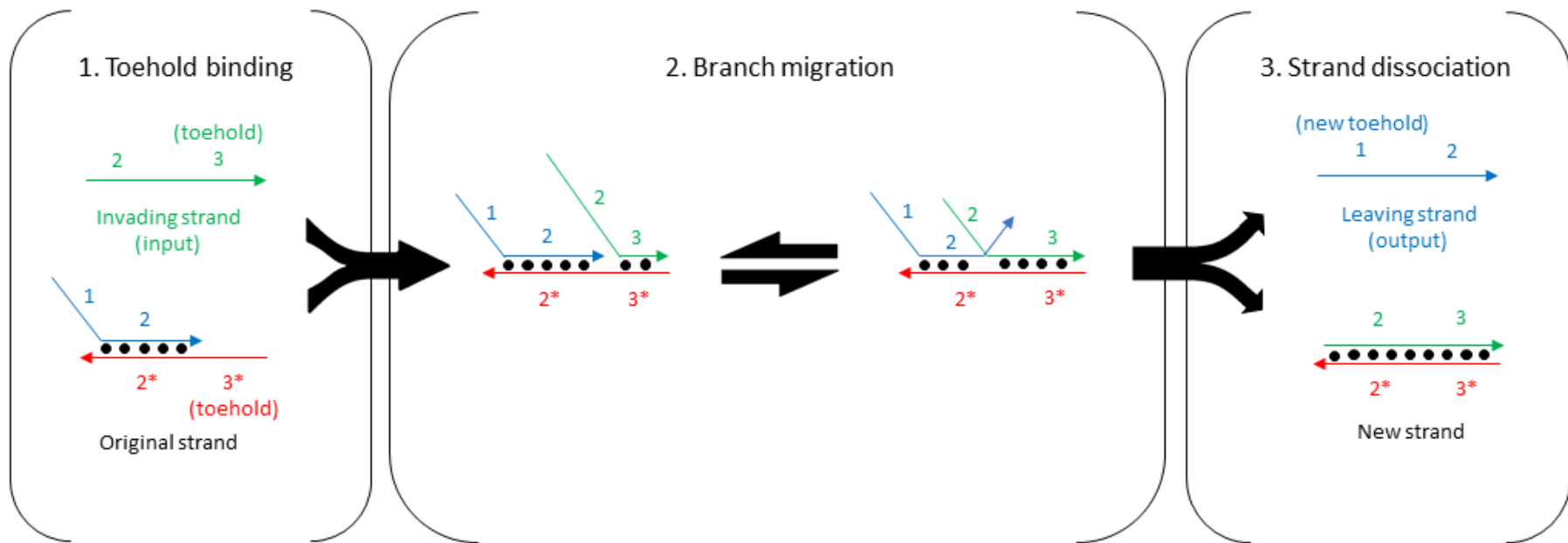

Toehold mediated strand exchange

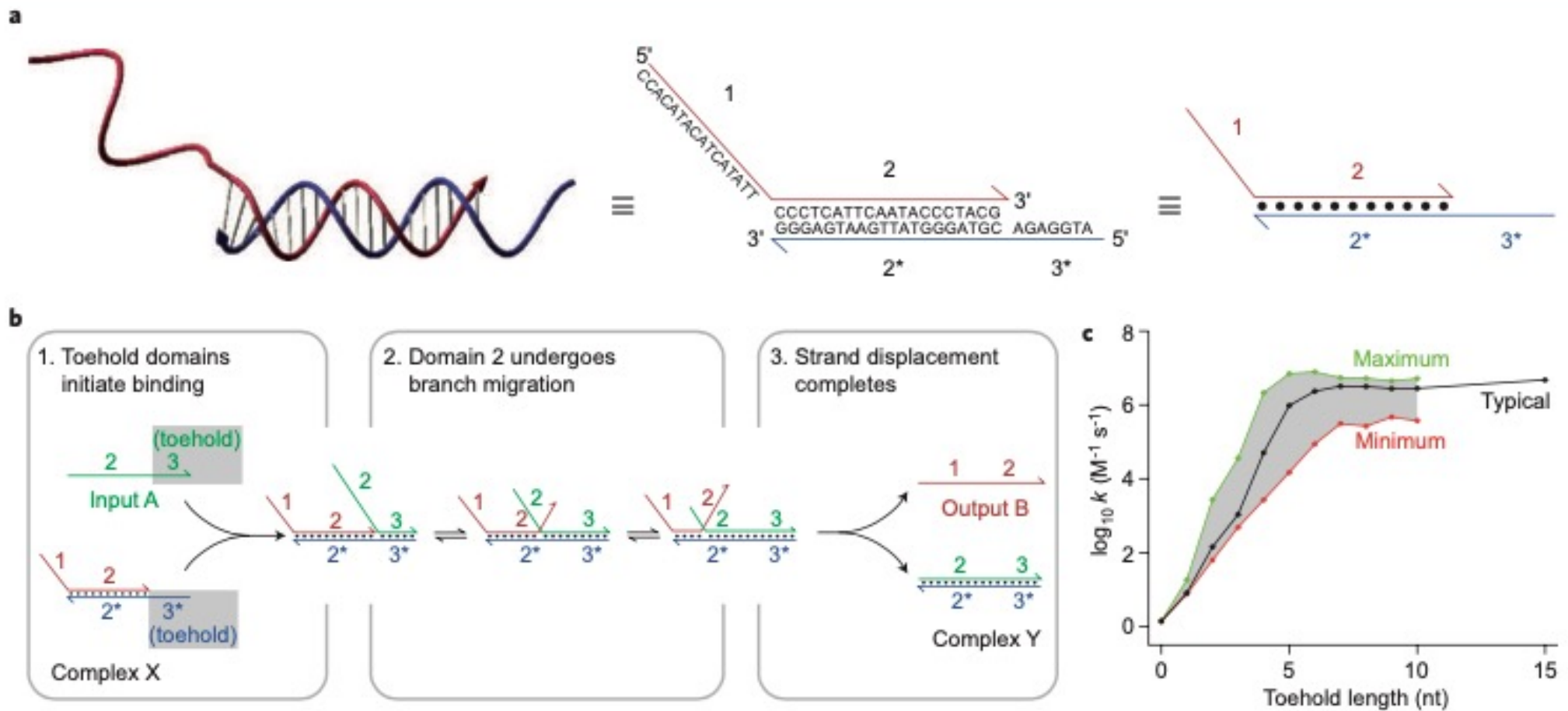

Toehold mediated strand displacement vs Toehold mediated strand exchange (where original strand melts off)

Toehold-Mediated Strand Displacement

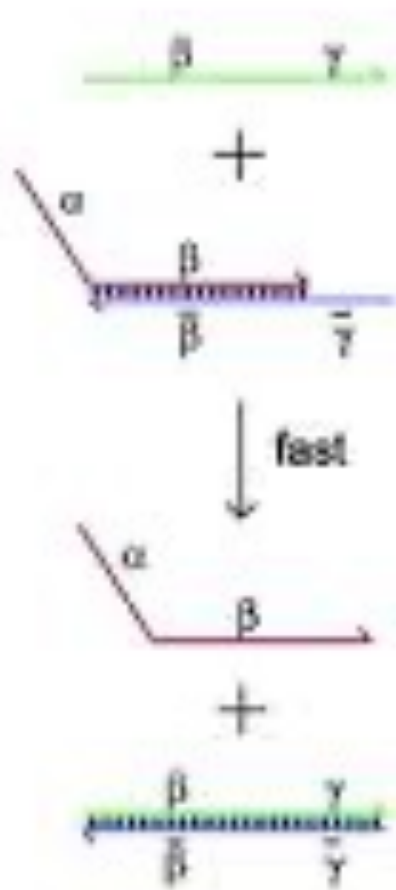

Toehold Exchange

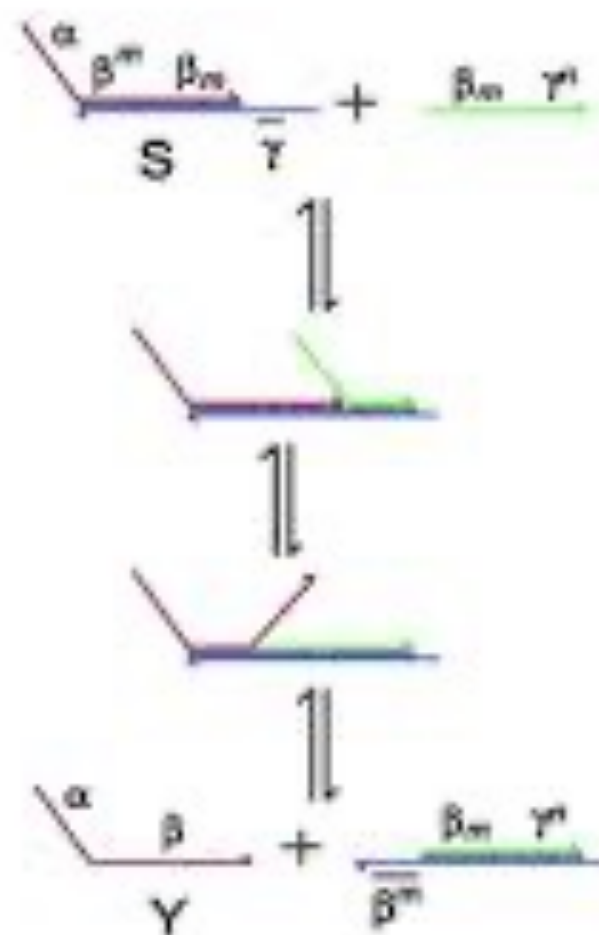

Kinetics of Toehold mediated strand displacement and exchange (Zhang and Winfree)

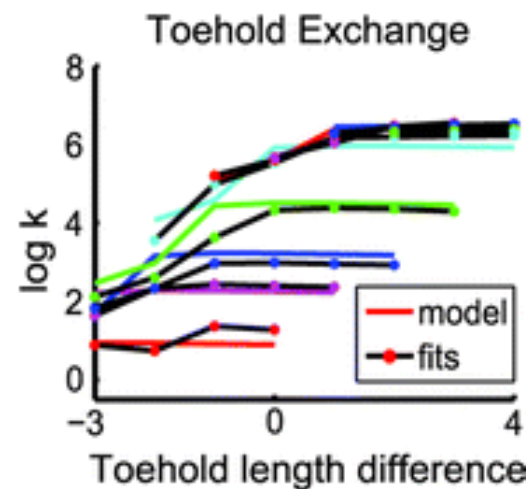
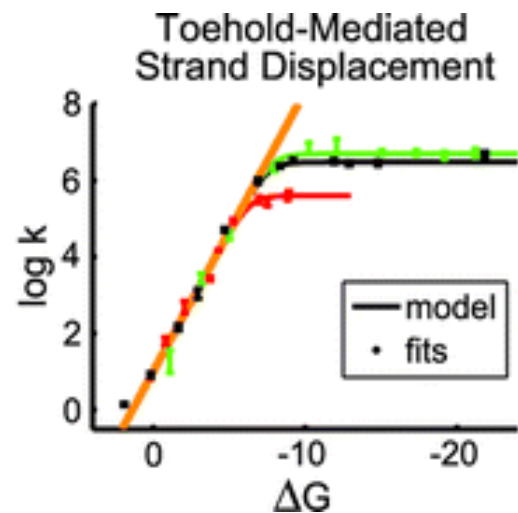
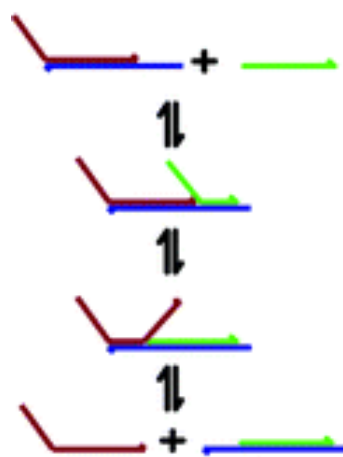
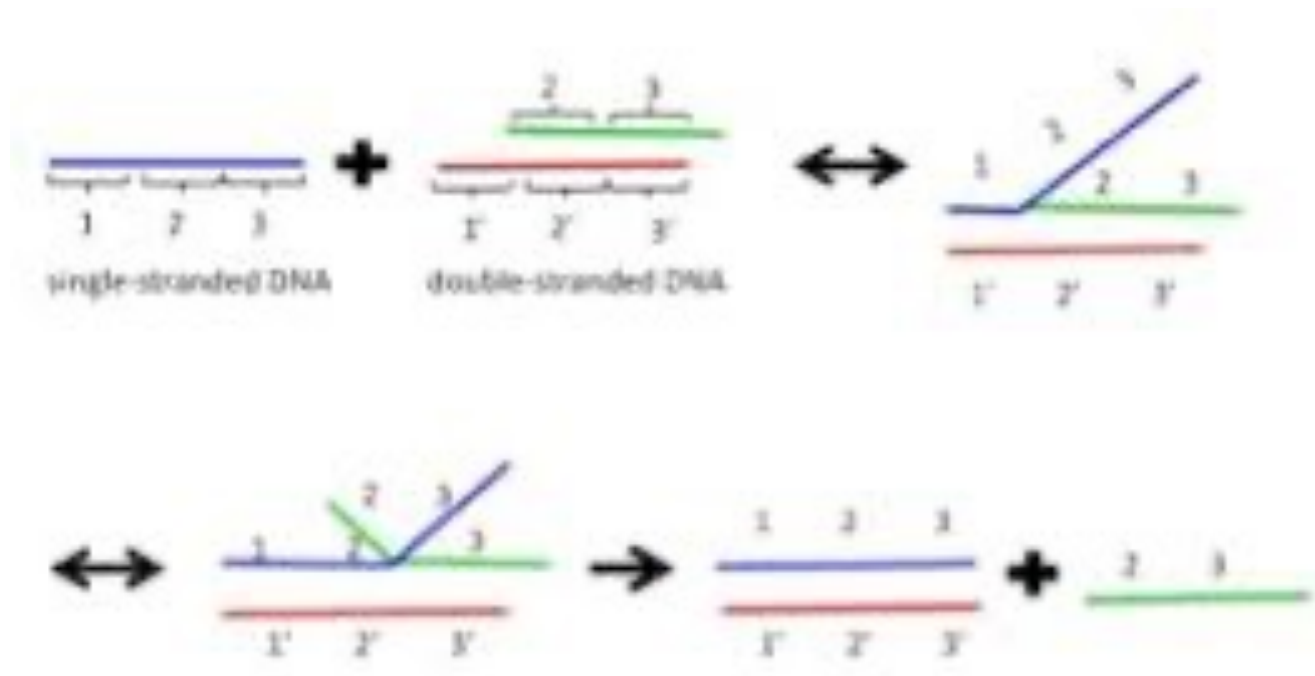

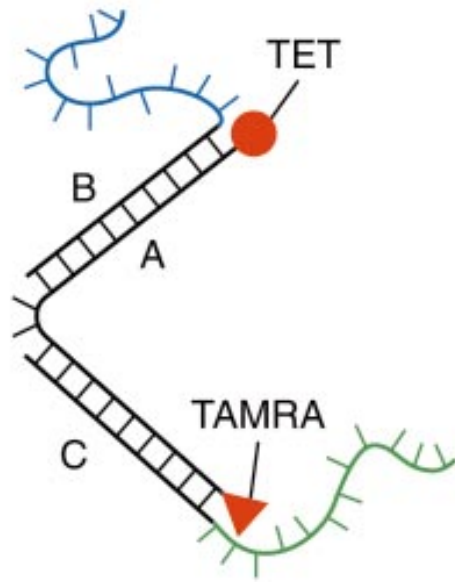
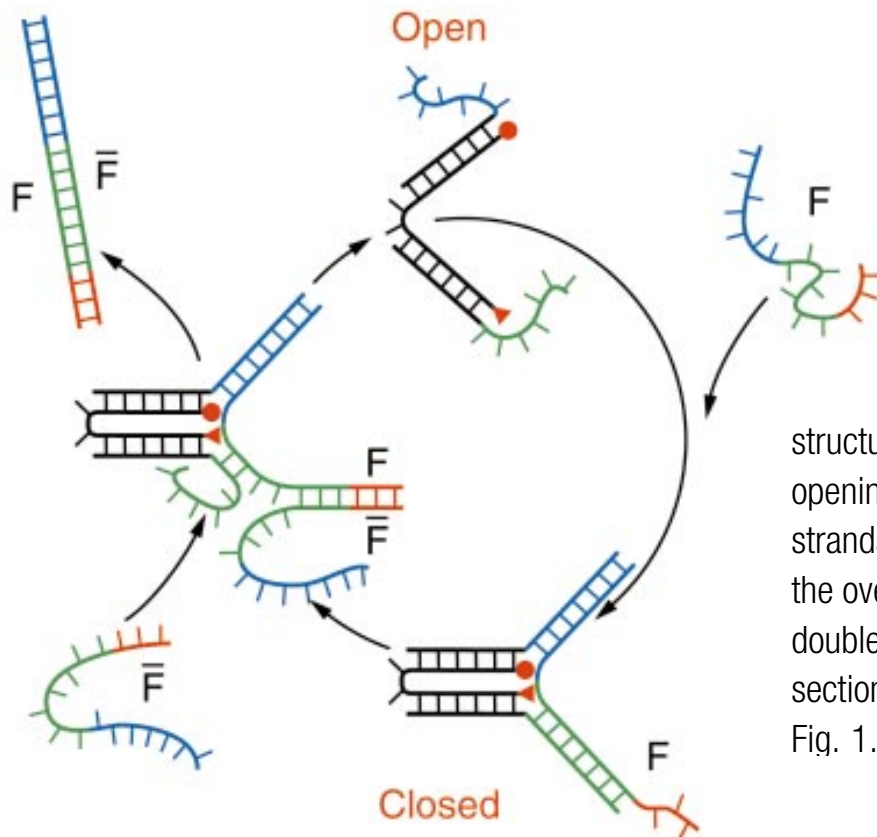
a**Open Position****b**

Yurke-Turberfield's DNA Tweezers: the invention of toe-hold mediated strand displacement

Yurke, B., Turberfield, A. J., Mills, A. P., Simmel, F. C. & Neumann, J. L. A DNA- fuelled molecular machine made of DNA.
Nature **406**, 605–608 (2000).

Construction and operation of the molecular tweezers. **a**, Molecular tweezer structure formed by hybridization of oligonucleotide strands A, B and C. **b**, Closing and opening the molecular tweezers. Closing strand F hybridizes with the dangling ends of strands B and C (shown in blue and green) to pull the tweezers closed. Hybridization with the overhang section of F (red) allows \bar{F} strand to remove F from the tweezers, forming a double-stranded waste product $\bar{F}F$ and allowing the tweezers to open. Complementary sections of B, C, F and \bar{F} that hybridize to close and open the tweezers are coloured as in Fig. 1.

Energetics of Yurke-Tuberfield's DNA Tweezers

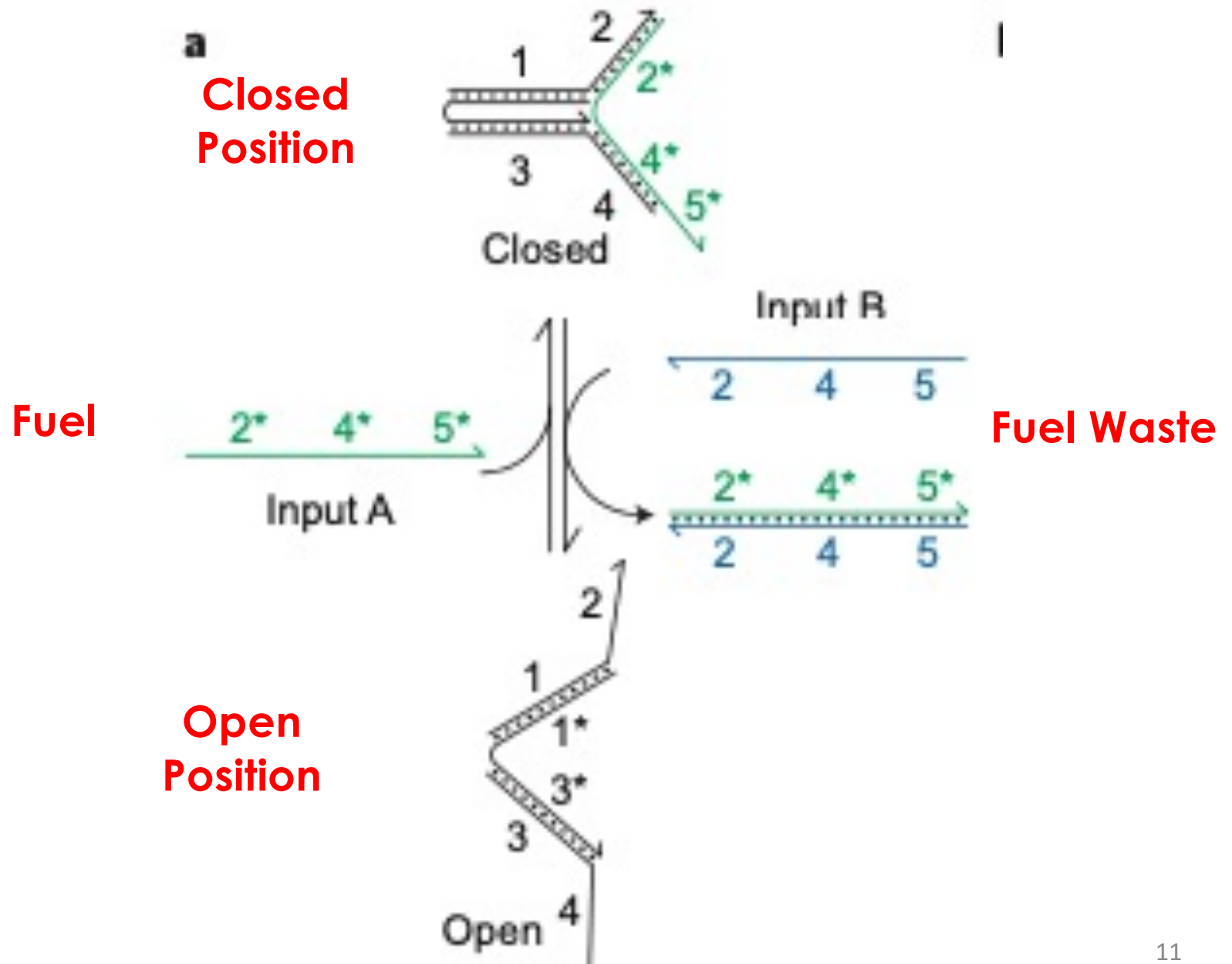

Rotary device using PX–JX₂ junctions controlled by toe-hold mediated strand displacement

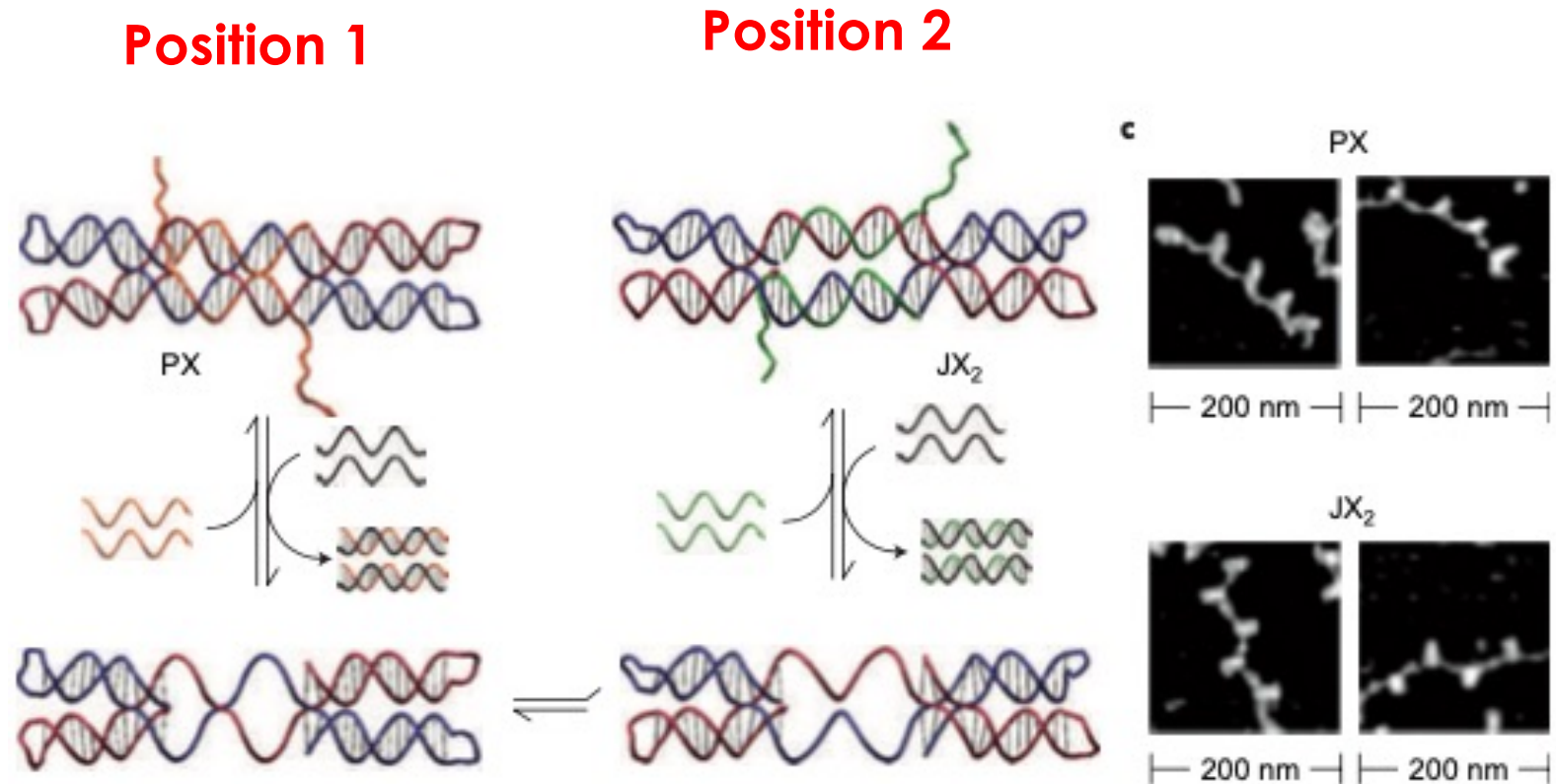

Yan, H., Zhang, X. P., Shen, Z. Y & Seeman, N. C.
A robust DNA mechanical device controlled by hybridization topology.
Nature **415**, 62–65 (2002).

Improvements to Toehold mediated strand displacement and exchange

A) Toehold-mediated strand displacement: The presence of a toehold (t) in the target strand (T) mediates the displacement of the incumbent strand (N) by the invader strand (I).

B) Associative toehold:

A reaction with a small proximal toehold (t) is accelerated by an auxiliary strand (M) complementary to the strands I and T. This mechanism effectively increases the length of t. However, it results in an IT product with the M strand strongly attached.

C) Handhold mediated strand displacement (HMSD):

The incorporation of a handhold (h) - an independent overhang in N - spatially constrains I to the vicinity of T, enhancing the efficiency of binding to short proximal toeholds in the target. This binding results in faster reaction rates while, for short handholds, allowing the complete detachment of I after the reaction.

D) Handhold-complementarity substantially enhances displacement rates for short toeholds:

A reporter (RQ) monitors the progress of HMSD reactions by interacting with the displaced domain in N and fluorescing. We plot representative results for a reaction with a 2 nucleotide (nt) proximal toehold and a 7 nt handhold. All traces are fitted with a single set of reaction parameters, as outlined in Supplementary Note XVI. Conditions: [RQ]₀=15 nM, [TN]₀=10 nM, [I]₀=[7-4] nM, 1M NaCl in 1x TAE at 25°C. Inset: Kinetics for 6nM of the I-strand without handhold-complementarity (grey).

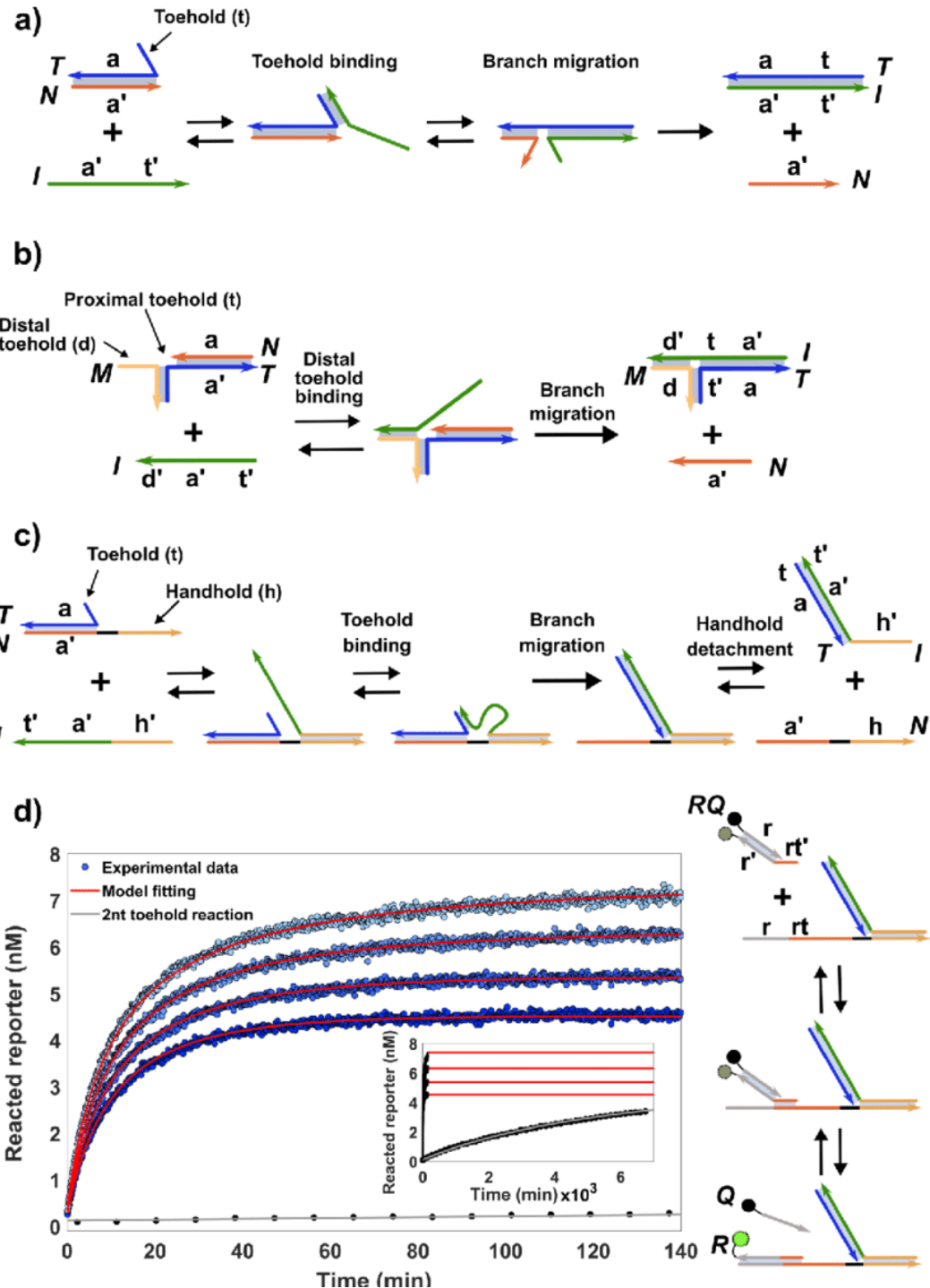

Abstract Diagrams for Seesaw Gates

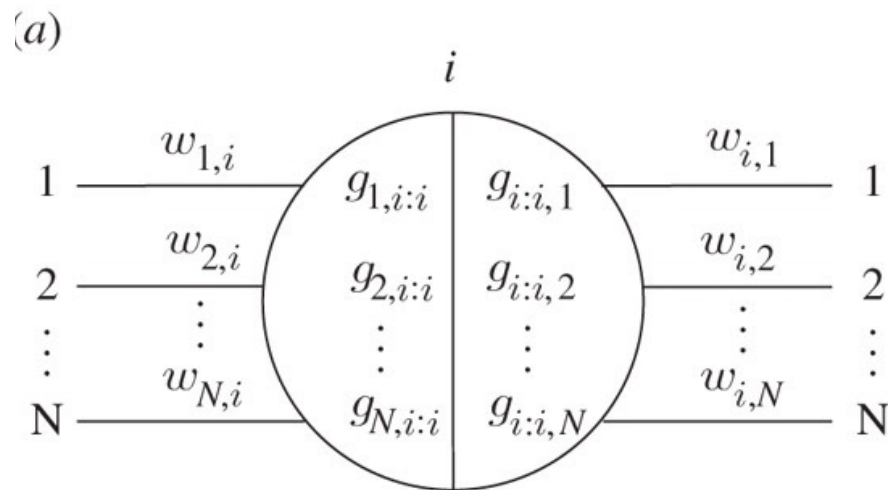

(a) The general form of a gate node i:

For each wire from the right side of gate i to the left side of gate j:

$w_{i,j}$ = the initial concentration of the input signal (written above the wire),

$g_{j,i:i}$ = the initial concentrations of gate complex (amount of $w_{j,i}$ bound to gate i)

$g_{i:i,j}$ = the initial concentrations of gate complex (amount of $w_{i,j}$ bound to gate i)

Both written within the node at the ends of the corresponding wires.

$th_{j,i:i}$ = initial concentrations of the threshold for $w_{j,i}$ arriving at gate i.

$th_{i:i,j}$ = initial concentrations of the the threshold for $w_{i,j}$ arriving at gate i.

(may be written in the same locations as $g_{j,i:i}$ and $g_{i:i,j}$, but as negative numbers)

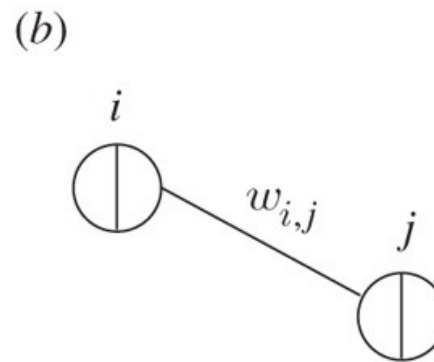

(b) The general form of a wire:

Each wire is specifically connected on its left end to the right side of a gate node, and connected on its right end to the left side of a gate node.

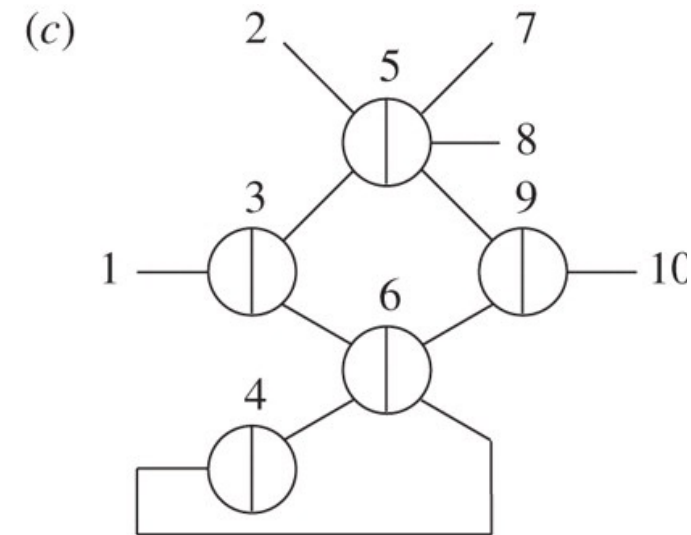

(c) An example circuit with five realized gates

(numbered circles), five virtual gates (numbers at ends of wires), and 11 wires.

Each wire is identified by the two gates it connects; thus the virtual gates serve to provide full names (and sequences) to their incident wires.

Note that circuit diagrams may be drawn without providing gate numbers, as they are not relevant to circuit function.

Details of Seesaw Gates

(a) **Abstract gate diagram:**
Red numbers indicate initial concentrations.

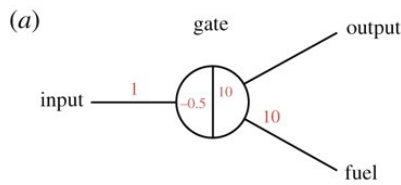

(c) **The threshold motif and reaction mechanism:**
The toehold is extended by a few bases (s'_1 , the complement of the first few 5' bases of S_1), providing an increased rate constant relative to the gate itself. Branch migration intermediate states are omitted from the diagram.

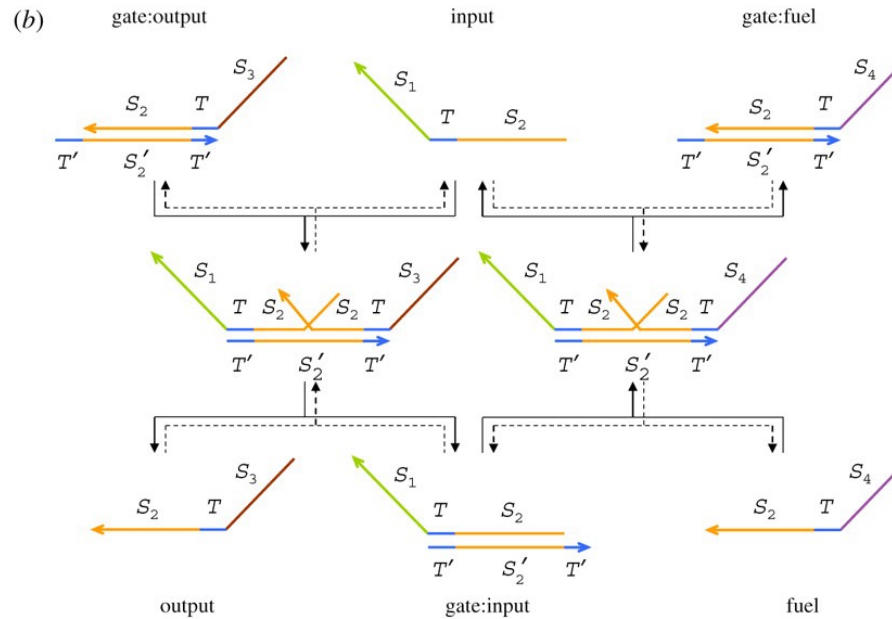
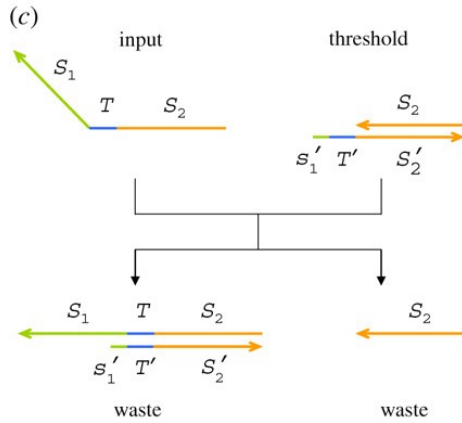

(d)	input $w_{1,2}$ ($1x$)		S_1 T S_2 <ACCTCTCATCTATCA CCACC TCTTTATCAATCTAC<
	gate:output $g_{2,2,3}$ ($10x$)		S_2 T S_3 <TCTTTATCAATCTAC CCACC TCCCACAACTTCAT< >GGTGGAGAAATAGTTAGATGGGTGG> T' S'_2 T'
	fuel $w_{2,4}$ ($10x$)		S_2 T S_4 <TCTTTATCAATCTAC CCACC CATCCCCATTACC<
	threshold $th_{1,2,2}$ ($0.5x$)		S_2 <TCTTTATCAATCTAC< >AGTGGTGGAGAAATAGTTAGATG> s'_1 T' S'_2

(d) **Example sequences:**

Gate complexes and signal molecules are shown at the domain level (second column) and at the sequence level (third column). Here, recognition domain sequences are 15 nt, the toehold domain sequence is 5 nt, and the toehold is extended by 3 nt for the threshold. Other lengths are possible, so long as they ensure that recognition domains will not spontaneously dissociate, toehold exchange is fast, and thresholding is sufficiently faster.

(b) **The DNA gate motif and reaction mechanism:**

S_1 , S_2 , S_3 and S_4 are the recognition domains; T is the toehold domain; T' is the Watson-Crick complement of T , etc. Arrowheads mark the 3' ends of strands. Signal strands are named by their domains from 3' to 5', i.e. from left to right, so the input is S_1TS_2 ; gate base strands and threshold bottom strands are named by their domain from 5' to 3'.

All reactions are reversible and unbiased; solid lines indicate the dominant flows for the initial concentrations shown in (a), while the reverse reactions are dotted.

Behavior of Seesaw Gates

Circuit diagrams and input/output behaviour of Boolean logic gates:

Output wires with arrowheads indicate that a downstream load is assumed, which consumes signal strands as they are released.

(a) A two-input OR gate using 1 seesaw gate and the “1-4 scheme”:

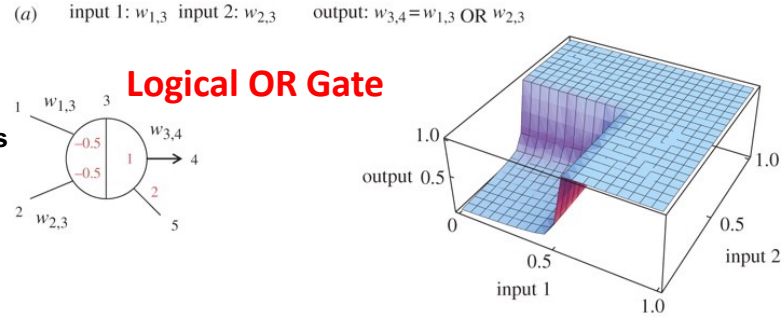

(b) A two-input AND gate using, respectively, 4 seesaw gates and the “1-4 scheme”:

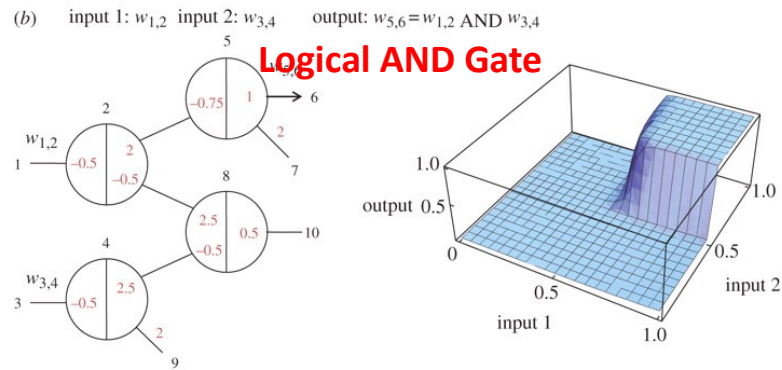

Note: Circuits constructed using the 1-4 scheme are not clean, and thus would perform worse if threshold crosstalk and threshold inhibition were modelled.

(c) A two-input OR gate using two seesaw gates, the “2-2 scheme”:

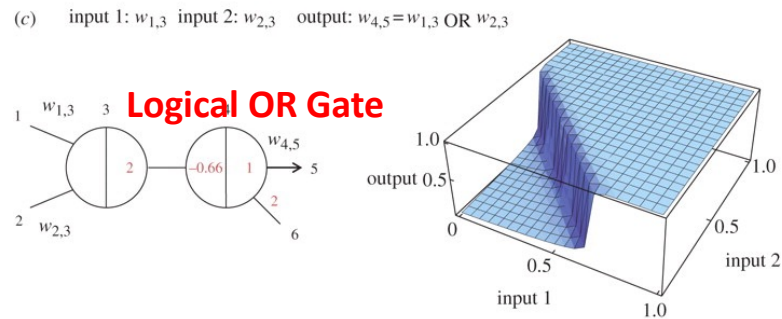

(d) A two-input AND gate using two seesaw gates each, the “2-2 scheme”:

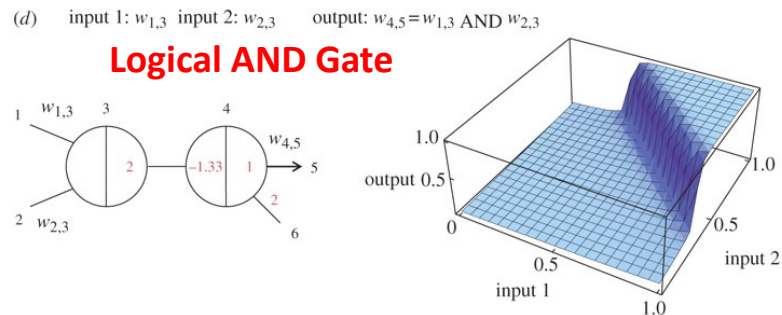

Seesaw Gates for Logic OR and AND

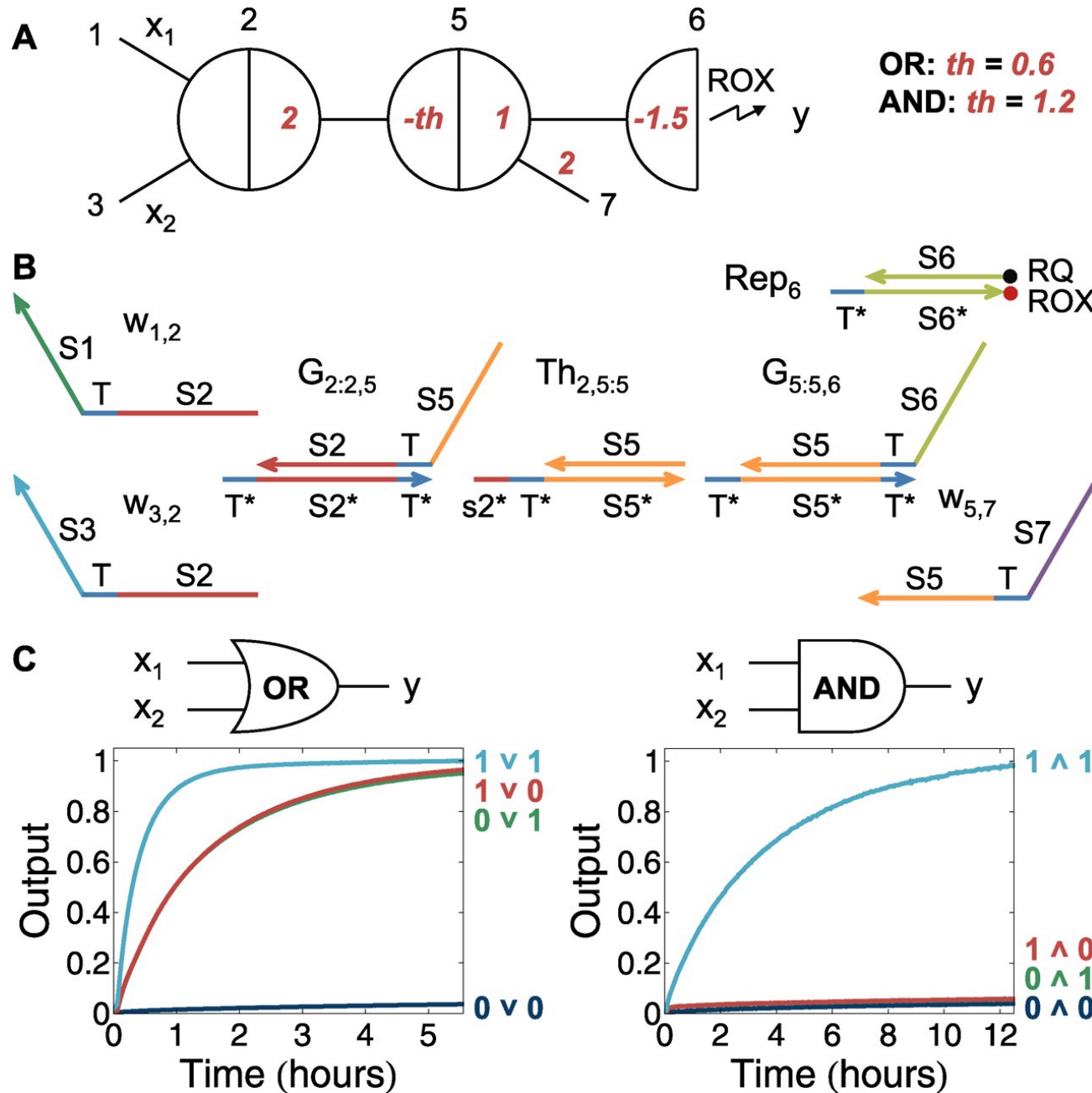

Boolean Logic using Seesaw Gates

Compiling Boolean logic circuits:

(a) A sample circuit with six gates:

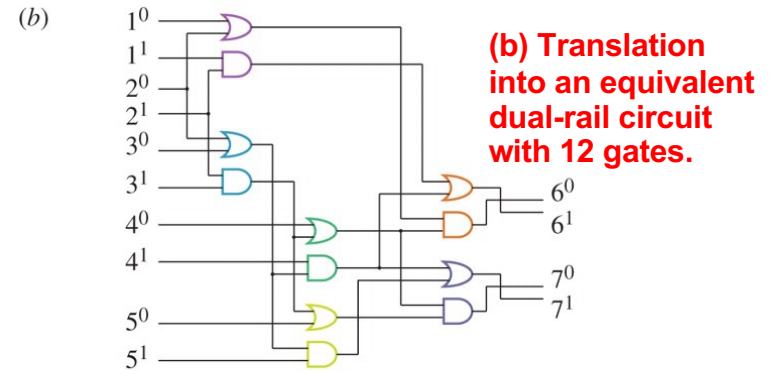
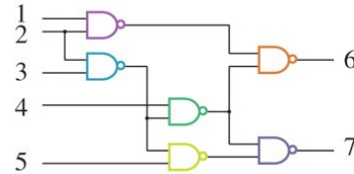

(c) Translation into an equivalent seesaw gate circuit with 32 gates (1-4 scheme).

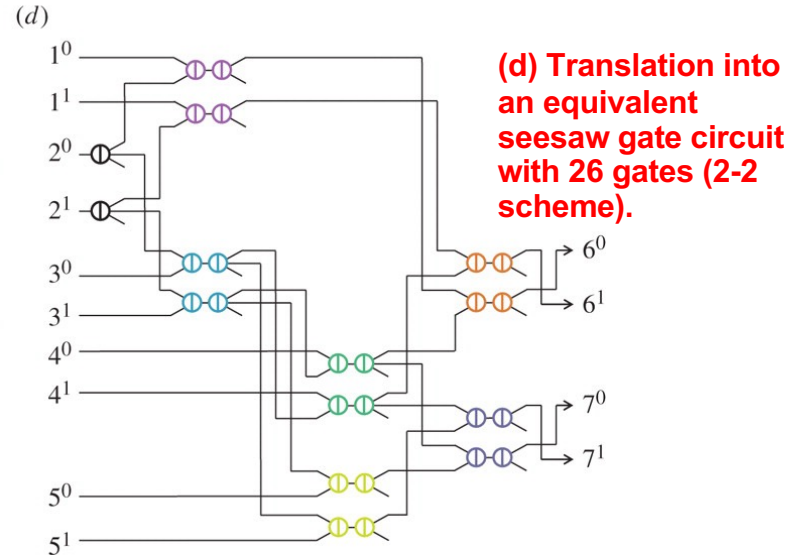
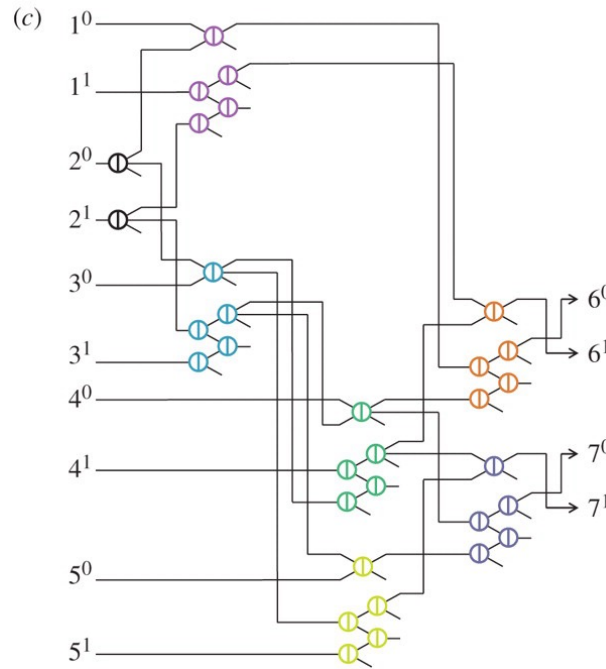

(e) Simulation results for all 32 possible input vectors in the 1-4 scheme:

For the 1-4 scheme, the simulated reaction equations were augmented to also model threshold crosstalk, which degrades the performance of OR gates—but the system still works.

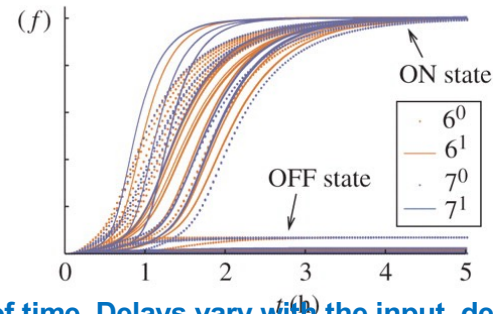
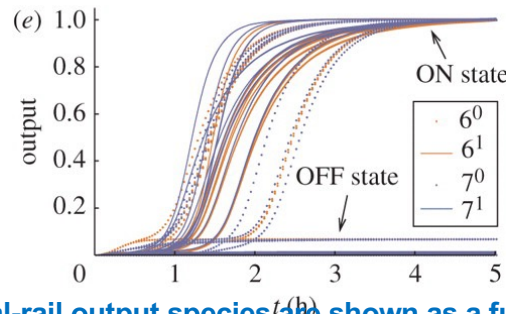

(f) Simulation results for all 32 possible input vectors in the 2-2 scheme.

The concentrations of all four dual-rail output species are shown as a function of time. Delays vary with the input, depending the shortest decision path through the network. Simulations were run using the concentration $1x = 50 \text{ nM}$, with ON inputs at $0.9x$ and OFF inputs at $0.1x$.

A Magnitude Comparator using Seesaw Gates

A 74L85 standard 4-bit magnitude comparator (four layers deep) and its seesaw circuit simulation, with $1x = 50$ nM.

(a) **(a) The digital logic circuit diagram.**
The corresponding seesaw circuit has roughly 100 seesaw gates:

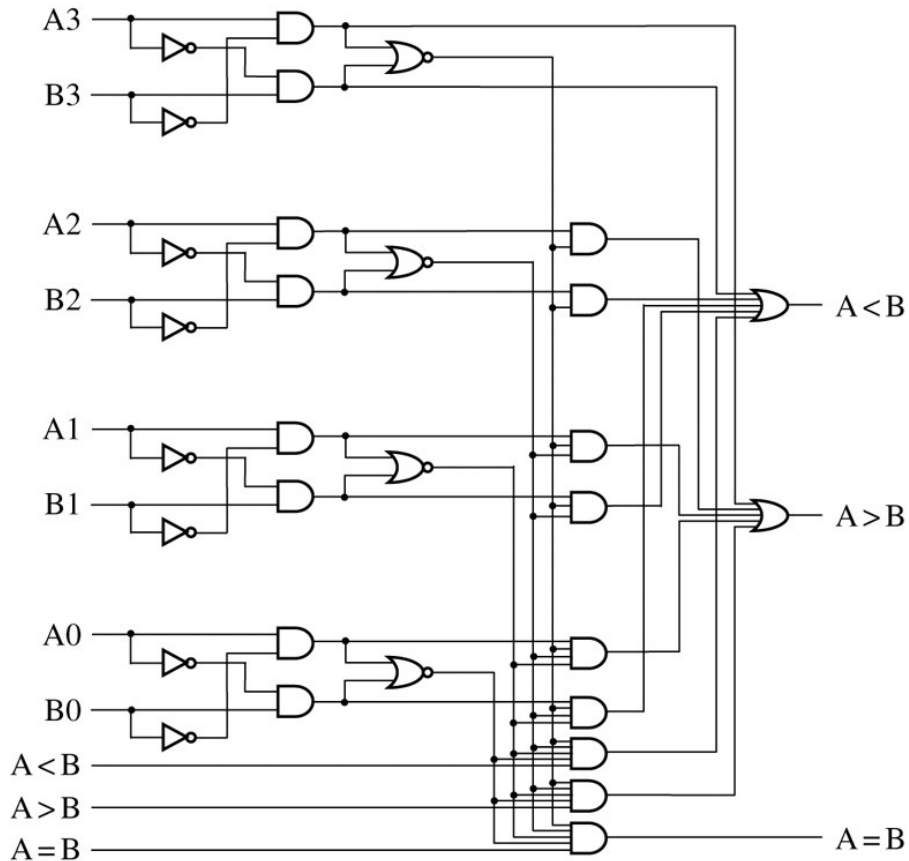

(b) $A[3:0]=[1,1,1,0]$ $B[3:0]=[0,1,1,1]$
 $[A < B, A > B, A = B]=[1,0,0]$

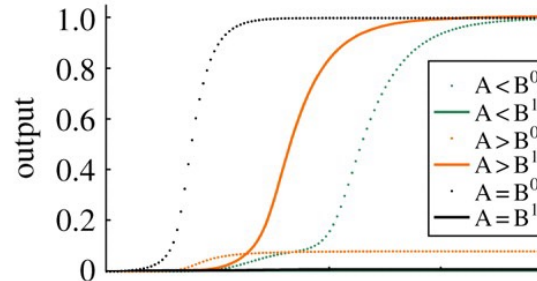

(b) Seesaw circuit simulation with selected input vector of A greater than B.

(c) $A[3:0]=[1,0,1,1]$ $B[3:0]=[1,1,0,1]$
 $[A < B, A > B, A = B]=[0,1,0]$

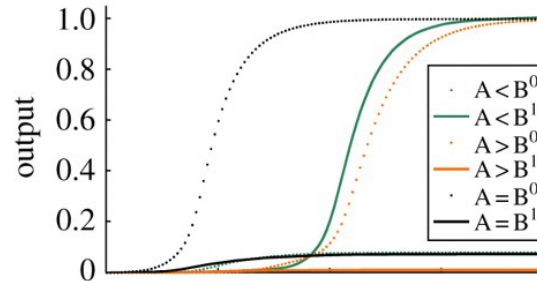

(c) Seesaw circuit simulation with selected input vector of A smaller than B.

(d) $A[3:0]=[1,1,0,1]$ $B[3:0]=[1,1,0,1]$
 $[A < B, A > B, A = B]=[0,0,1]$

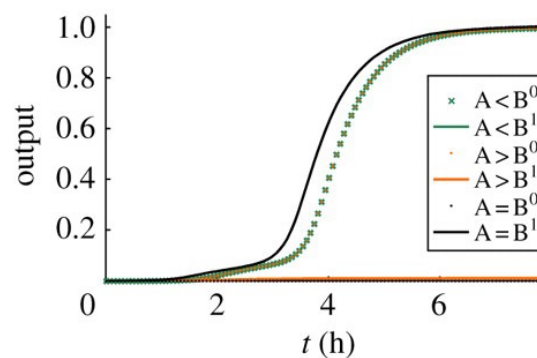

(d) Seesaw circuit simulation with selected input vector of A equal to B.

Relay circuits using Seesaw Gates

Shaded and unshaded sides of seesaw gates assist checking that a wire always connects different sides of two seesaw gates as required by node polarity, i.e. each wire connects the shaded side of one seesaw gate to the unshaded side of another. Switching signal A is provided at 1x if ON, or else 0.1x if OFF. Input current signal was provided at 10x; to verify that no output signal is produced when the current input is OFF, a 1x signal was provided.

(a) A simple circuit with current source (battery) and controlled device (denoted by a resistor), the corresponding seesaw gate circuit, and its simulation using 1x = 50 nM:

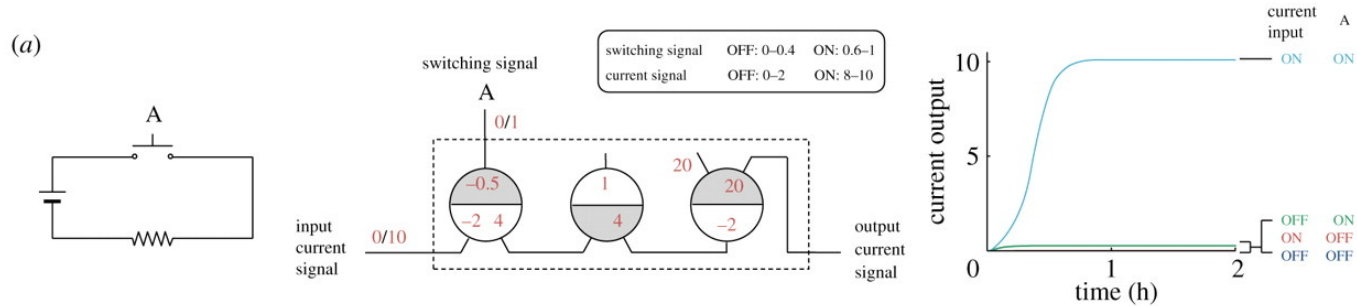

(b) AND logic Circuit:

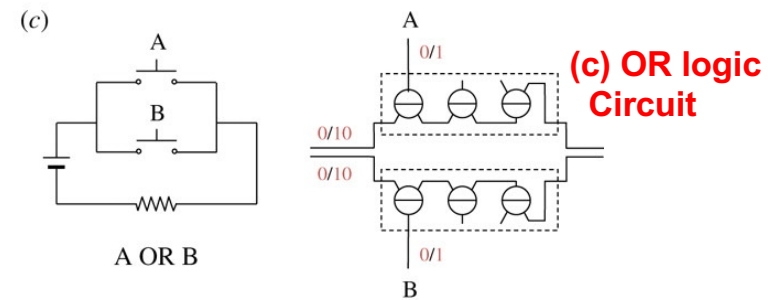
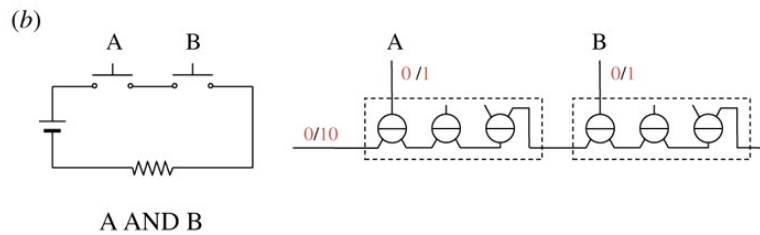

(d) A more complex circuit: Overlapping trajectories (orange and light blue) were shifted to the left by 100 s to make them visible.

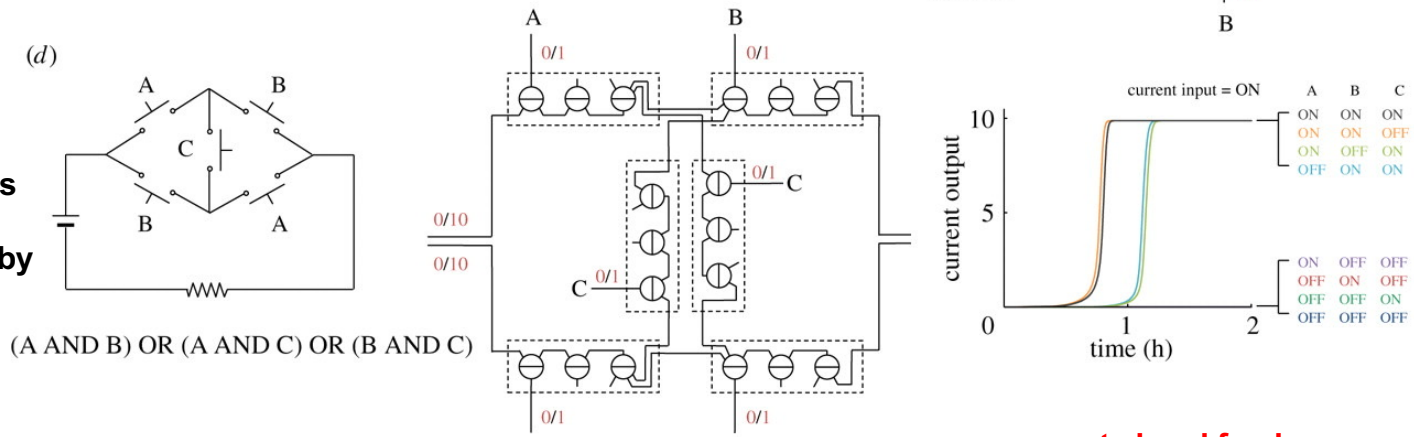

(e) Switching signal fan-out, current signal fan-out and current signal fan-in:

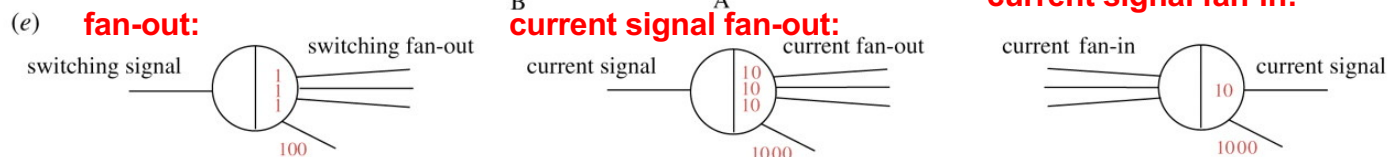

The seesaw gate motif and the construction of linear threshold gates.

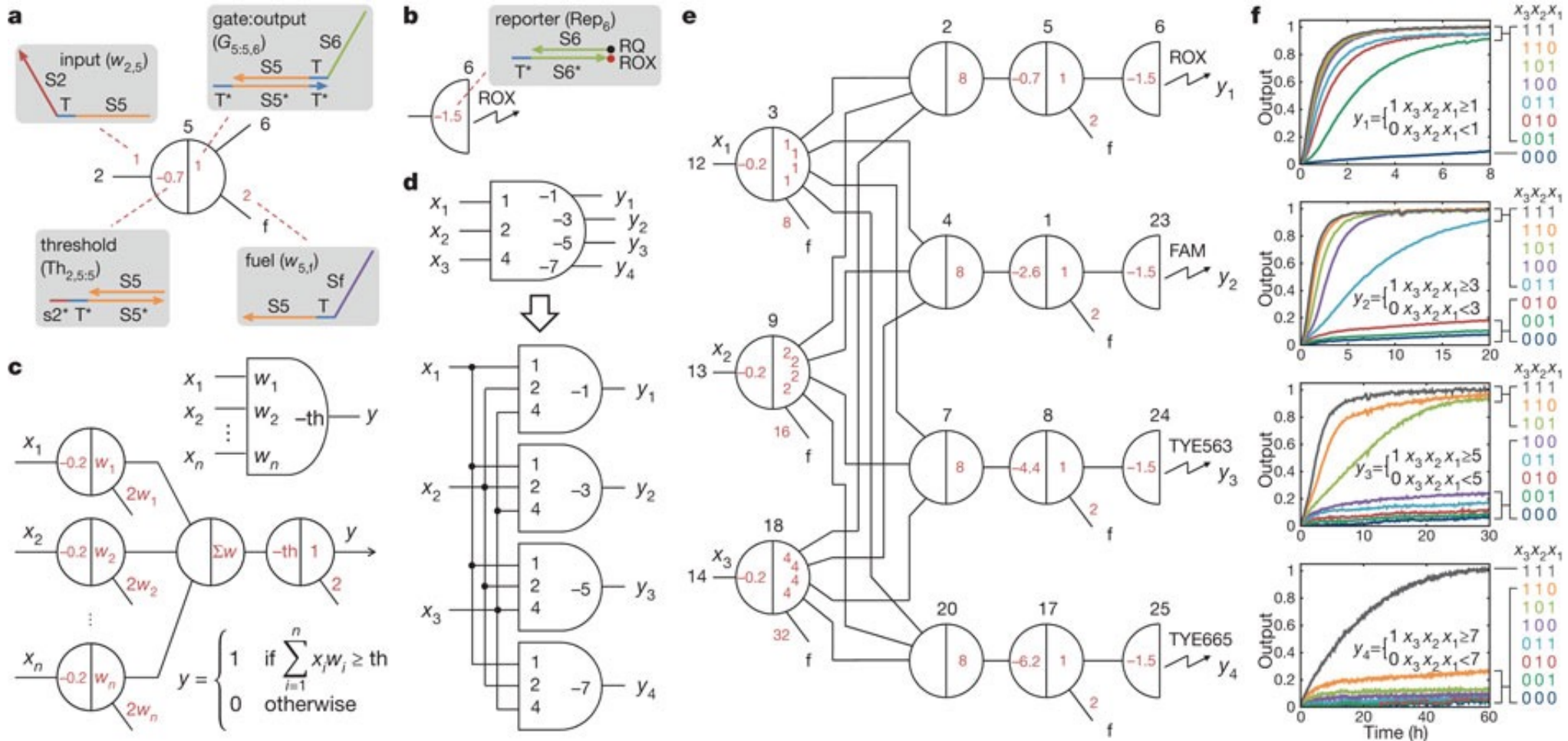

Analogue Circuits of Seesaw Gates

Analogue time-domain circuits.

(a) A catalytic cascade that exhibits initially quadratic growth:

Temporal trajectories are shown for a series of exponentially decreasing initial input concentrations.

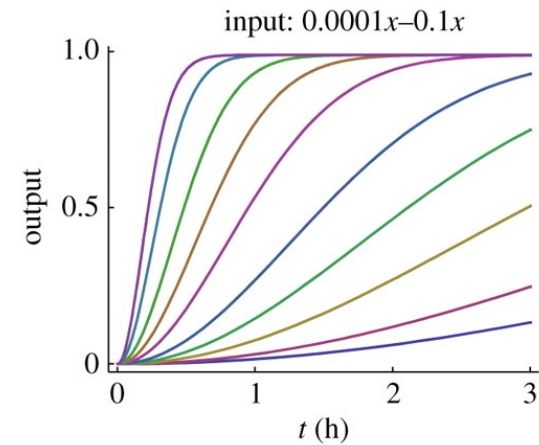
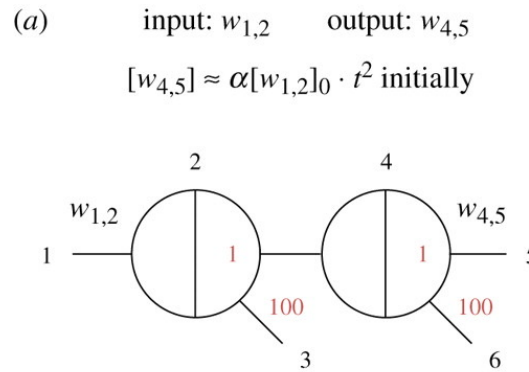

(b) A positive feedback circuit that exhibits initially exponential growth:

The same series of exponentially decreasing input concentrations now yields a series of trajectories with linearly increasing half-completion times.

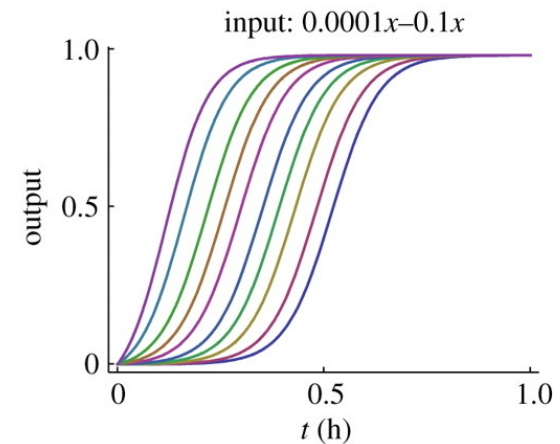
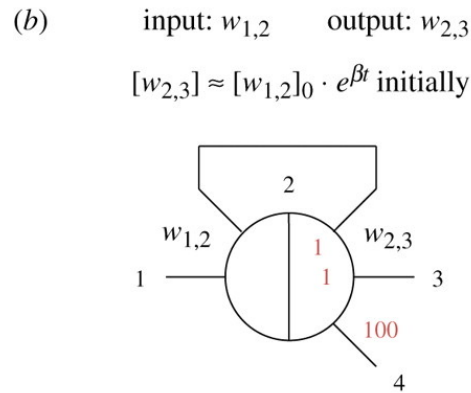

(c) A pulse-generating circuit:

Pulse amplitude depends on the input concentration. Here, we use a linear series of input concentrations between $0x$ and $1x$. All simulations use $1x = 50$ nM.

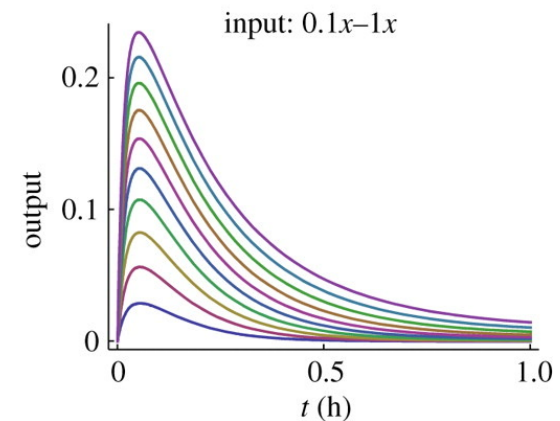
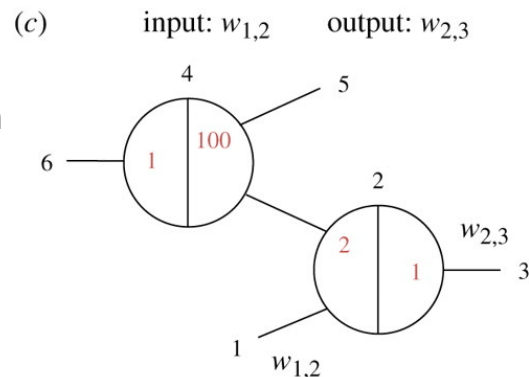

Parallel Preparation of Seesaw Gates

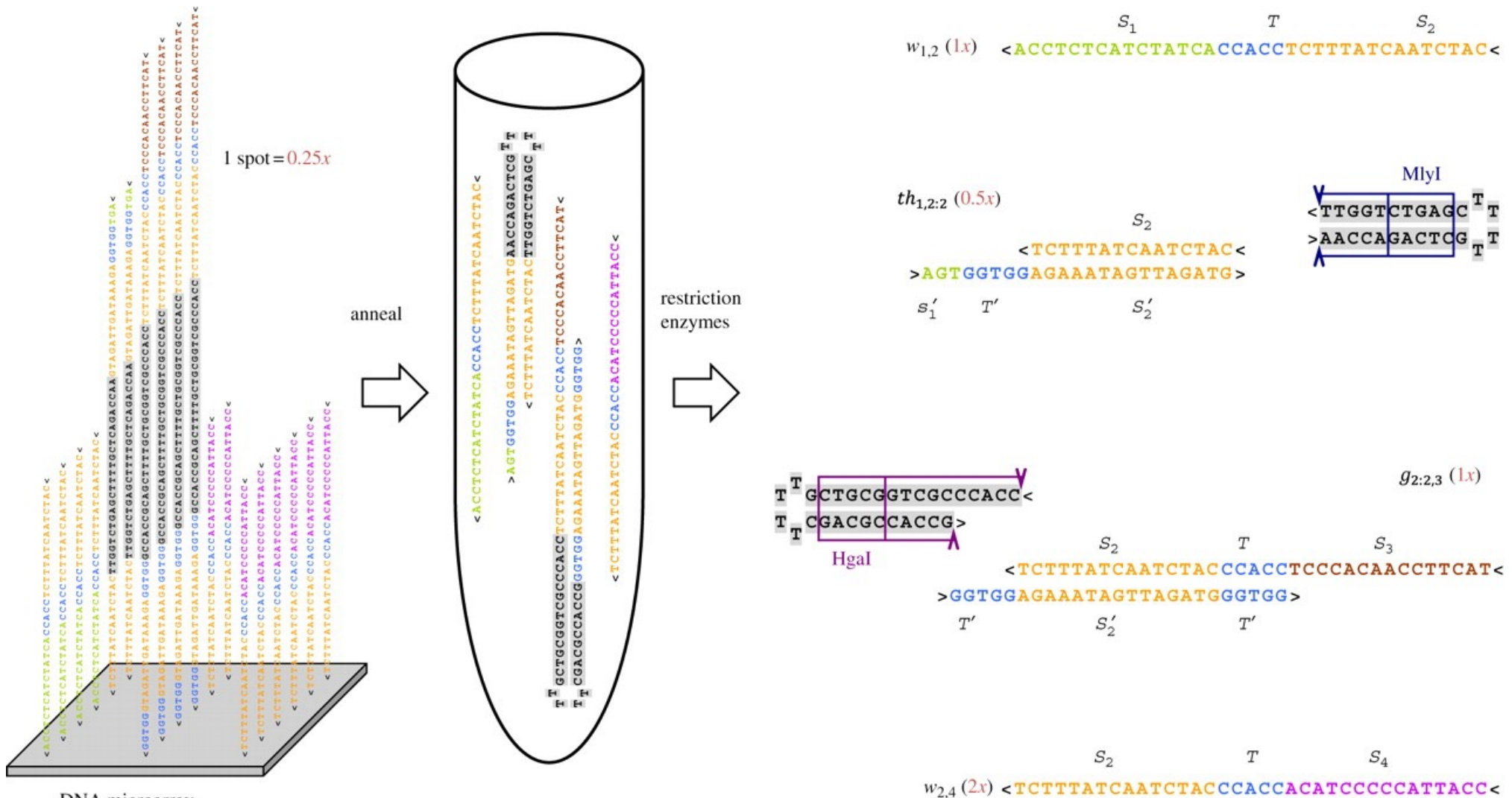

Parallel preparation of seesaw gates as hairpin precursors:

- Using DNA microarray synthesis technologies, each gate, threshold and fuel is made as a single strand. After cleavage from the surface, the mixture is annealed to form hairpins.
- Restriction enzymes then cleave the hairpins to form gate and threshold complexes.
- Relative concentrations (red numbers) are set based on the number of DNA chip spots dedicated to a given strand; in this example, one spot produces $0.25x$.

Catalysis: the increase in the rate of a chemical reaction due to the participation of an additional substance called a catalyst.

Catalytic Reaction:

A reaction with a Catalysis.

- The products of the reaction grow linearly with time.

DNA Catalytic Cascades

Catalytic DNA Systems

1. Catalytic system powered by increase in the number of bases paired.

G. Seelig, B. Yurke, and E. Winfree, *JACS* **129**, 12211 (2006).

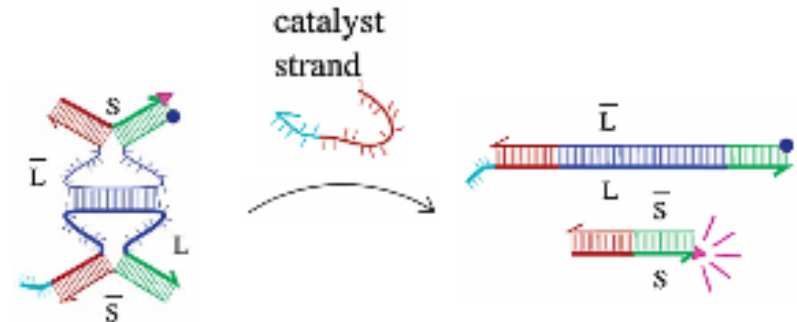

2. Catalytic system entropically driven by increase in the number of DNA strands.

D. Zhang, A. J. Turberfield, B. Yurke, and E. Winfree, *Science* **318**, 1121 (2007).

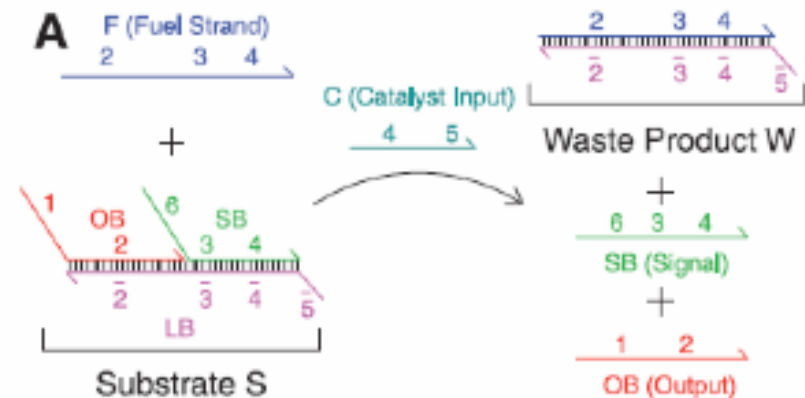

DNA Catalytic Cascades

Making a metastable fuel complex

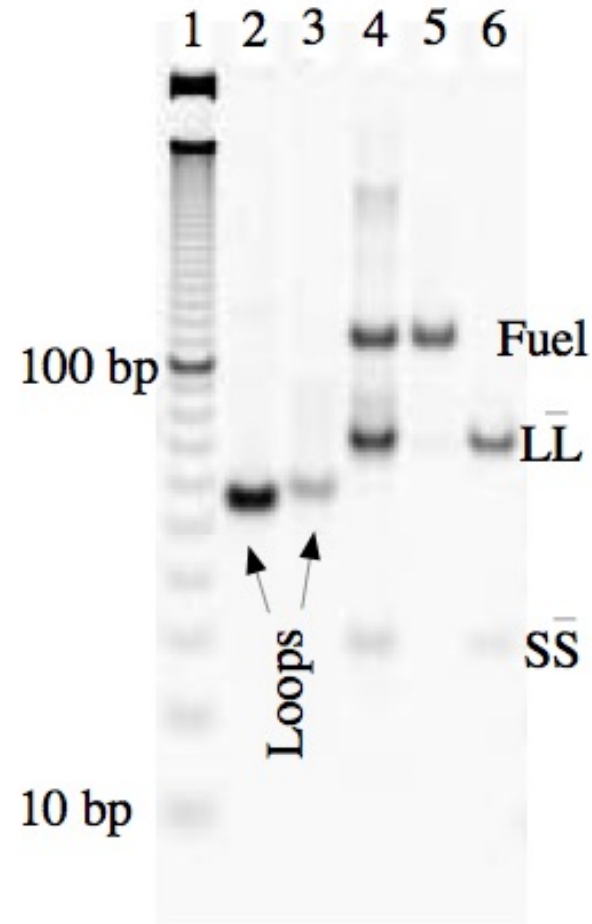
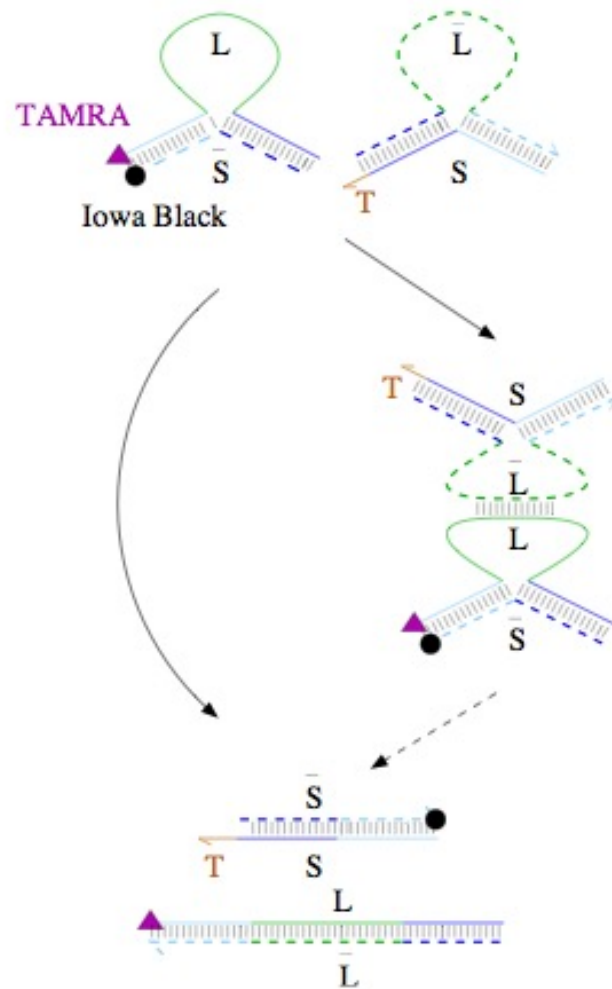

Seelig, et al., JACS 90, 12211 (2006)

DNA Catalytic Cascades

Catalytic speedup of fuel-complex decay

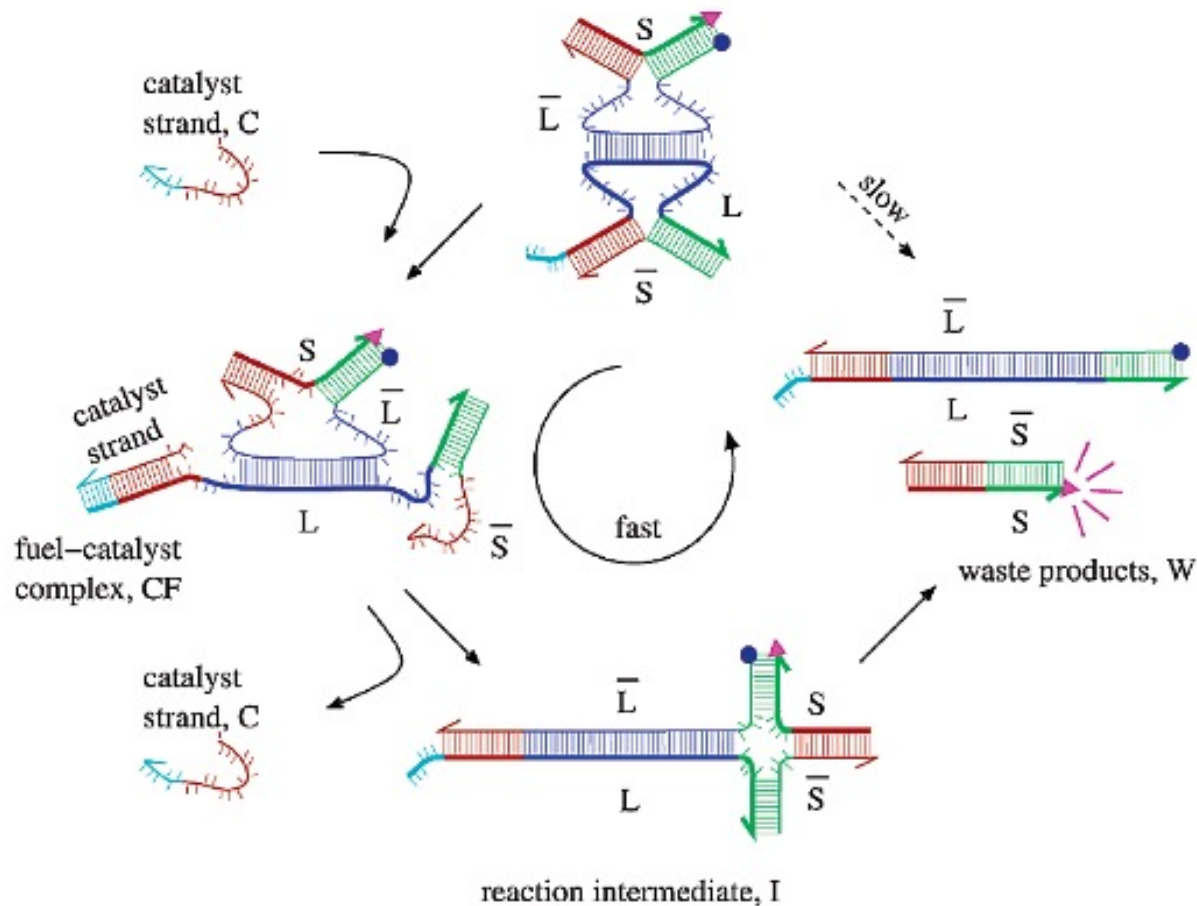

Seelig, et al., JACS 90, 12211 (2006)

DNA Catalytic Cascades

[fuel complex] = 200 nM, varying [catalyst]

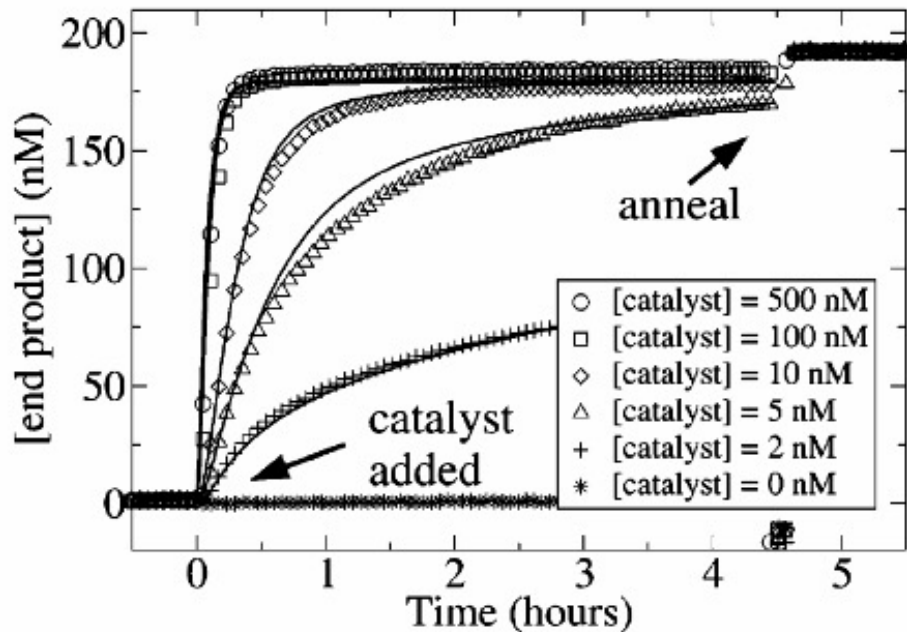

Catalytic speedup: 5000

Turnover : 40

Seelig, et al., JACS 90, 12211 (2006)

Energy content of the fuel

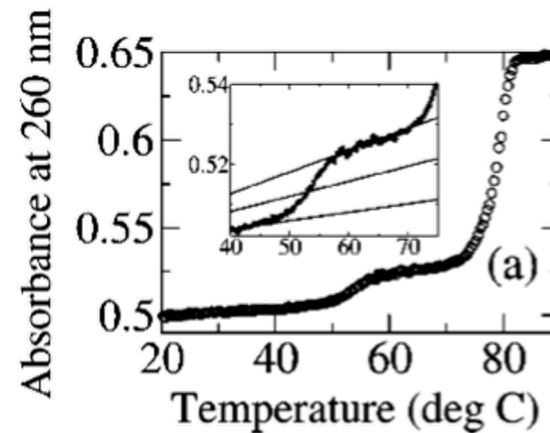

Free energy change due to the kiss
 $\Delta G_{\text{kiss}}^{\circ} = -23 \text{ kcal/mol}$

Free energy change do to decay of the fuel complex into waste products
 $\Delta G_{\text{stored}}^{\circ} = -55 \text{ kcal/mol}$

Free energy change do to decay of ATP into ADP
 $\Delta G_{\text{ATP}}^{\circ} = -7.3 \text{ kcal/mol}$

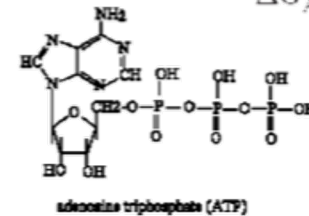
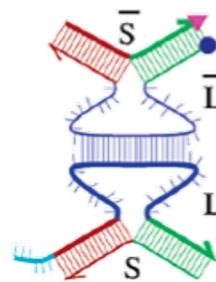

Seelig, et al., JACS 90, 12211 (2006)

DNA Catalytic Cascades

Entropy drive catalyst

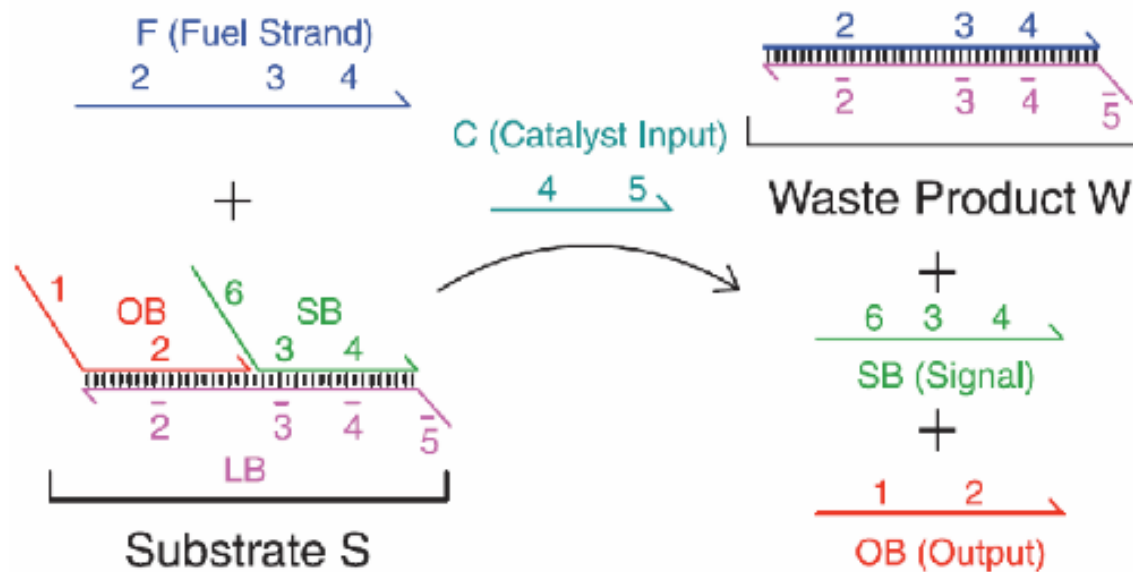

D. Zhang, A. J. Turberfield, B. Yurke,
and E. Winfree, *Science* **318**, 1121
(2007).

DNA Catalytic Cascades

Entropy drive catalyst

A

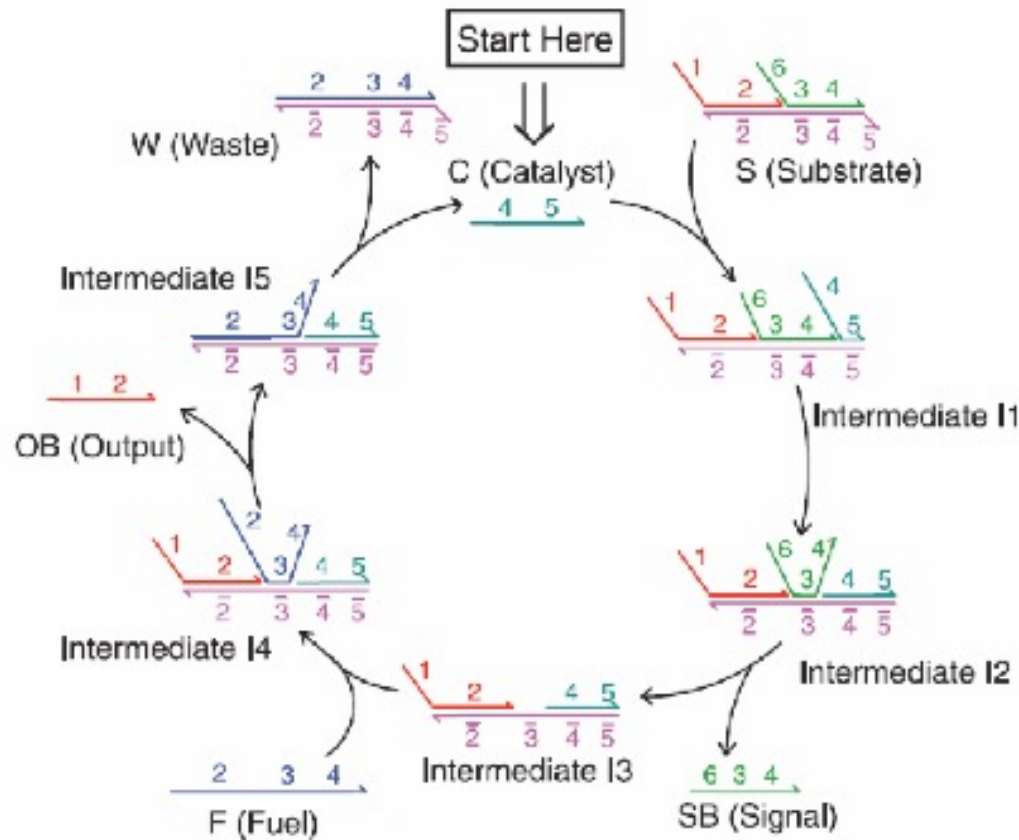

Zhang, et al., *Science* **318**, 1121 (2007).

Catalytic cycle

Domain 3 is four bases long.

B

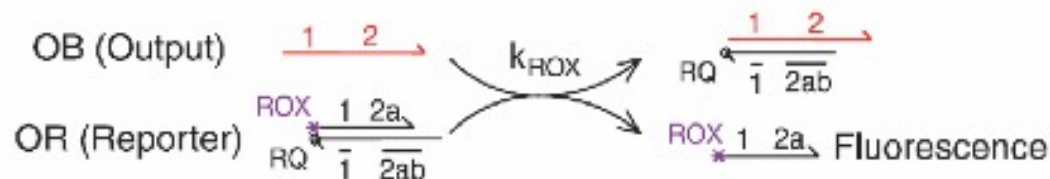

Readout scheme

DNA Catalytic Cascades

Entropy driven catalyst

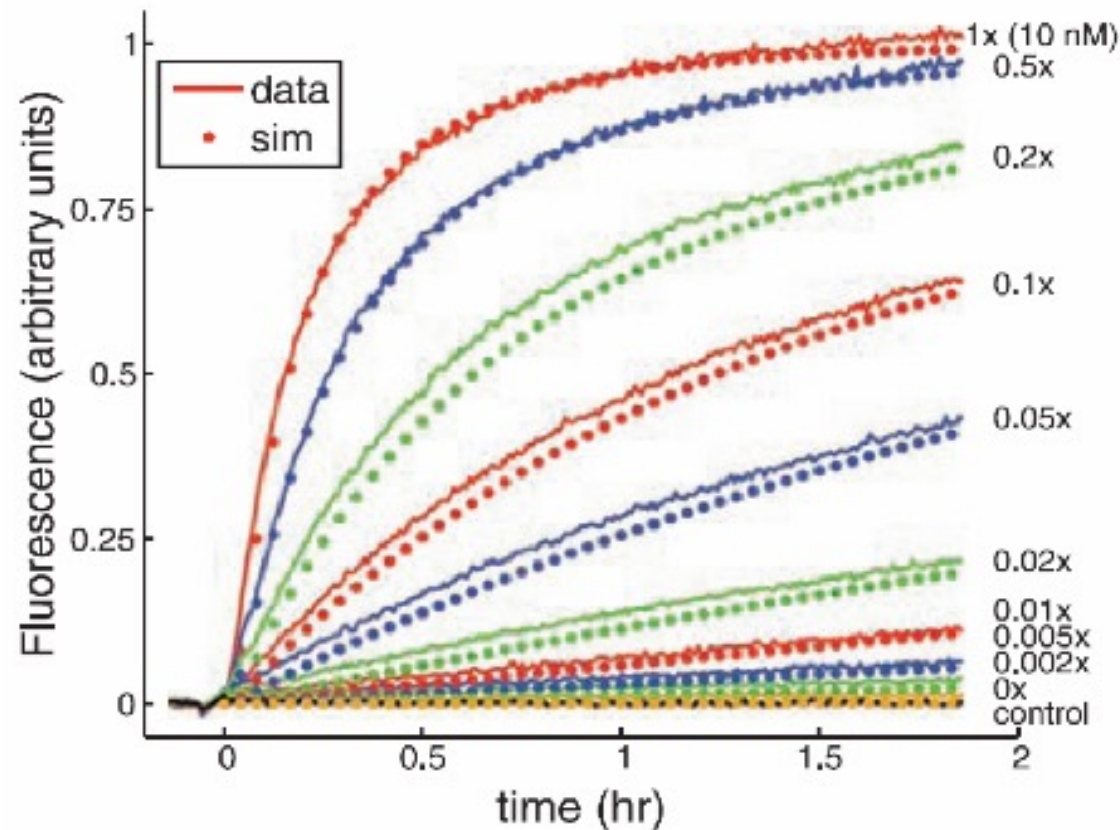

Catalytic speedup: 1.9×10^4

Zhang, et al., Science
318, 1121 (2007).

DNA Catalytic Cascades

Using entropy to go uphill energetically

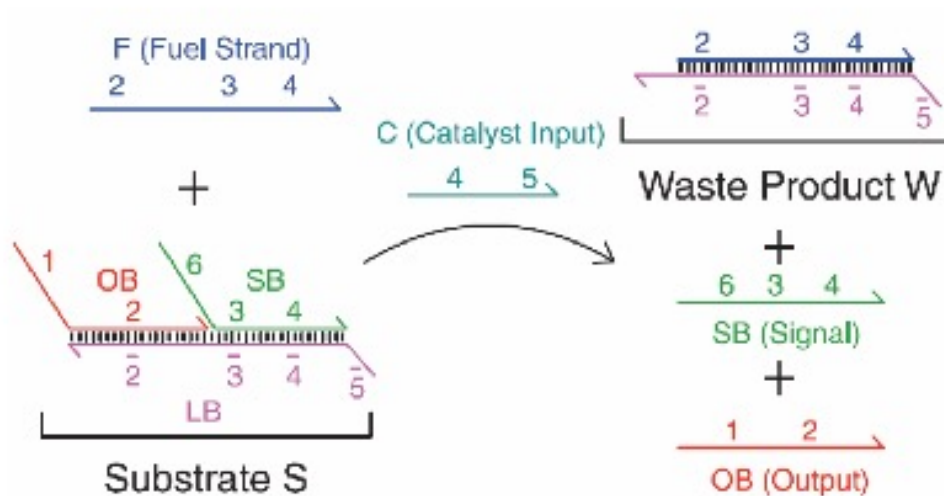
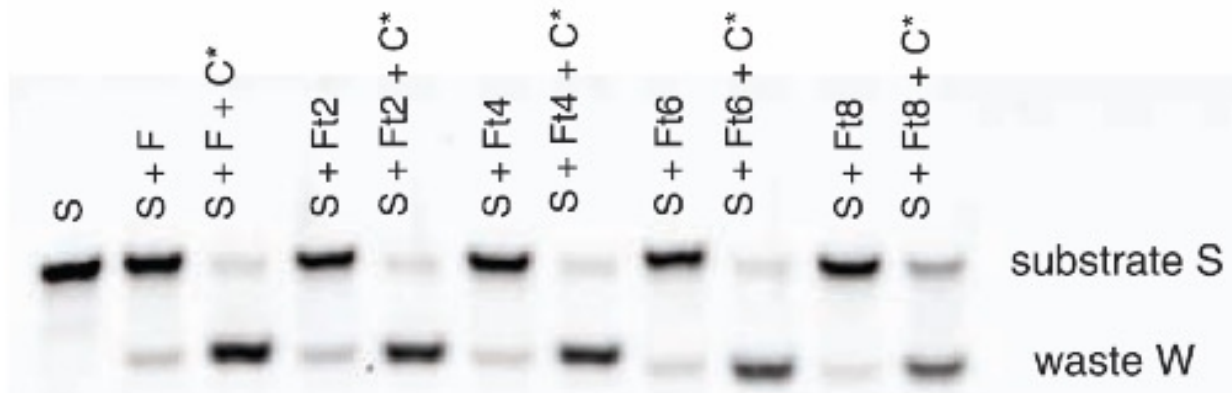

Zhang, et al., Science
318, 1121 (2007).

DNA Catalytic Cascades

A catalytic cascade

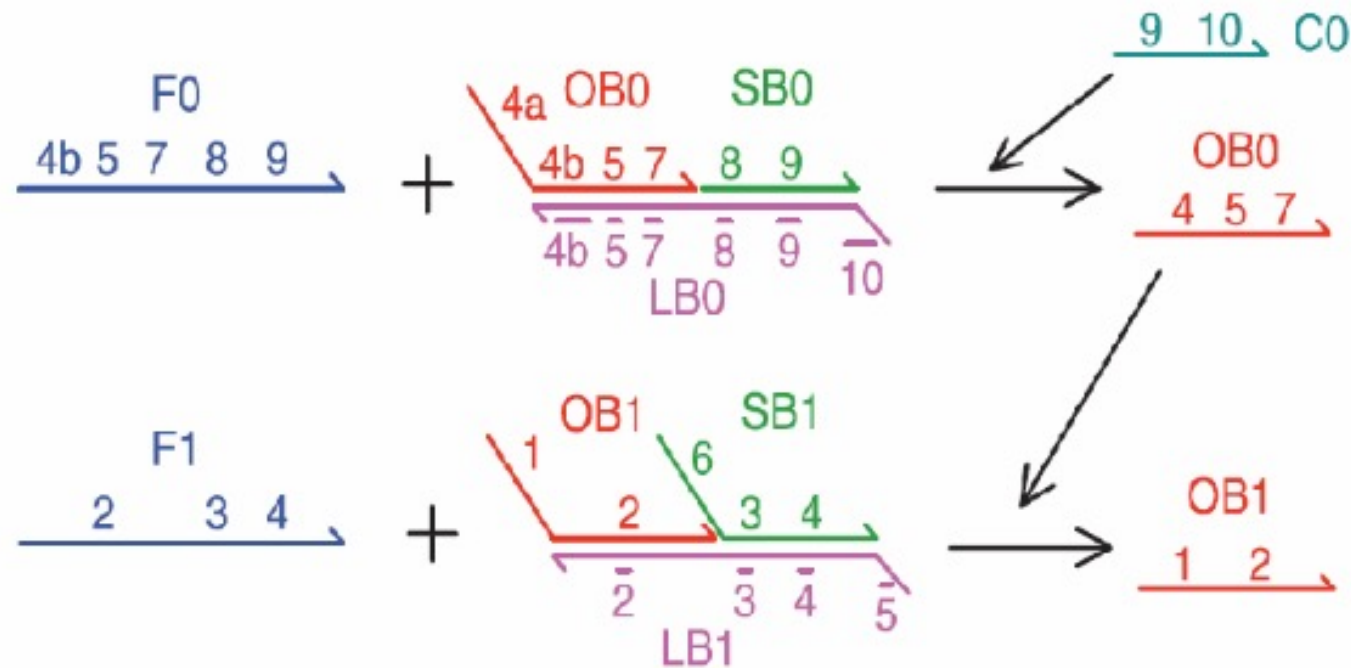

[C0] is constant with time

For short times

[OB0] is proportional to t

[OB1] grows as t^2

Zhang, et al., Science
318, 1121 (2007).

DNA Catalytic Cascades

A catalytic cascade

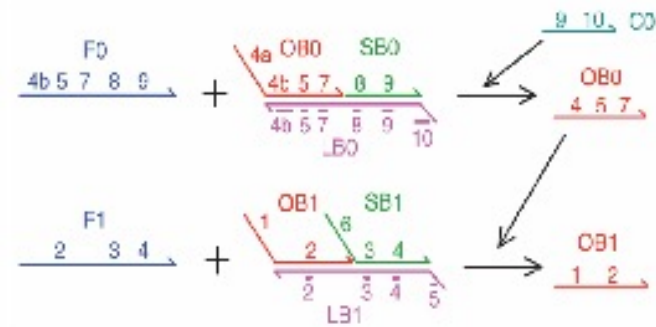
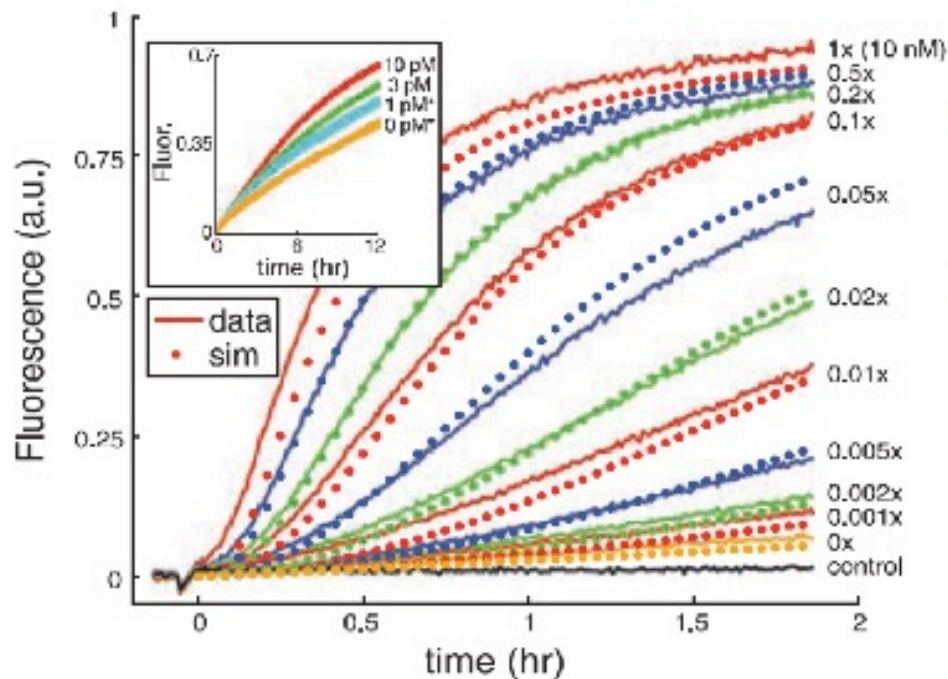

After 12 hours we can reliably distinguish between 0 pM and 1 pM of catalyst. 1 pM of catalyst generated 900 pM of reporter.

This is 900 fold amplification.

1 pM corresponds to about one molecule per eukaryotic cell.

Zhang, et al., *Science* **318**, 1121 (2007).

DNA Catalytic Cascades

An autocatalytic system

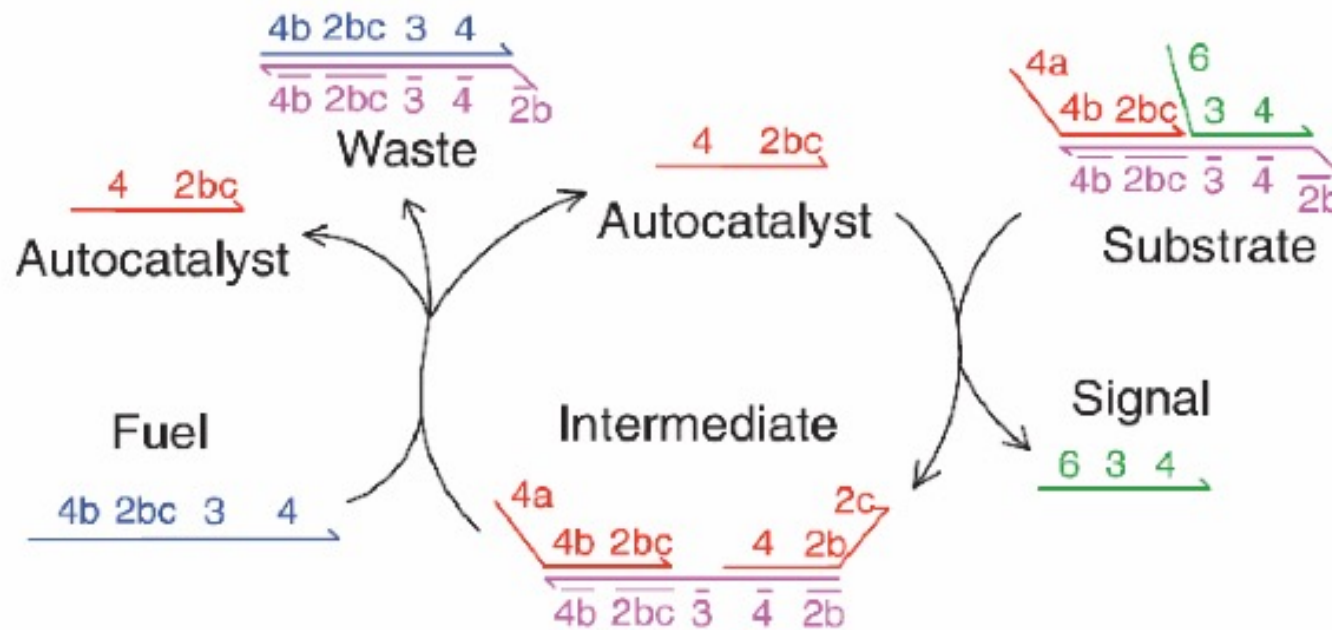

Zhang, et al., Science
318, 1121 (2007).

DNA Catalytic Cascades

Exponential growth with saturation

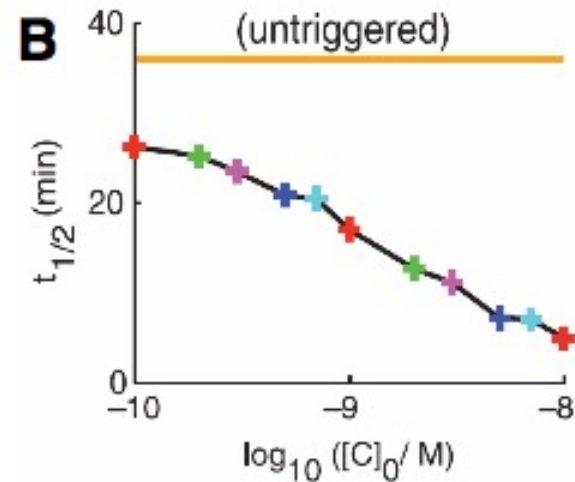
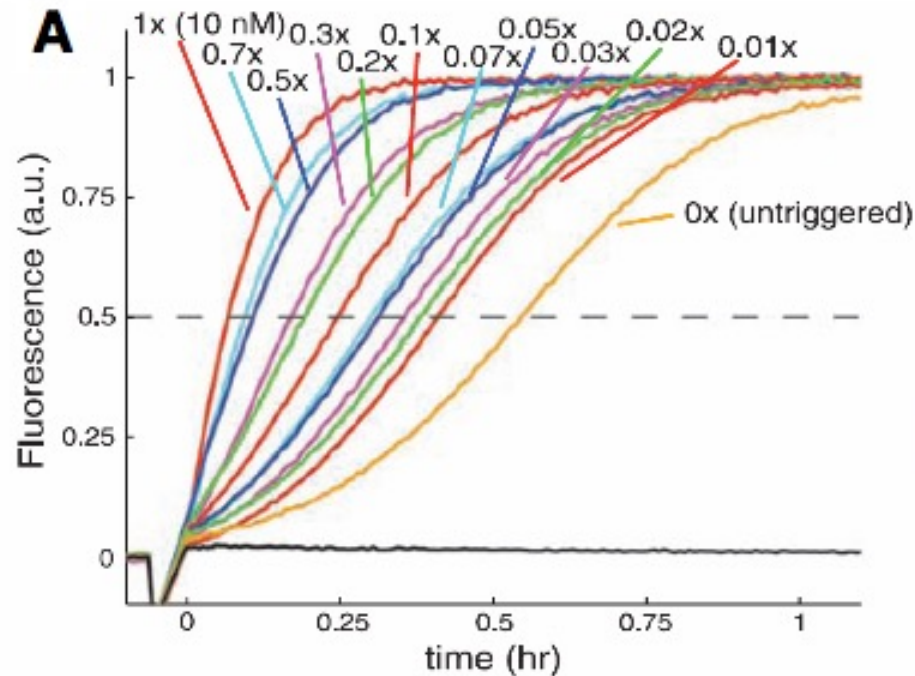

Zhang, et al., Science
318, 1121 (2007).

DNA Reaction Networks

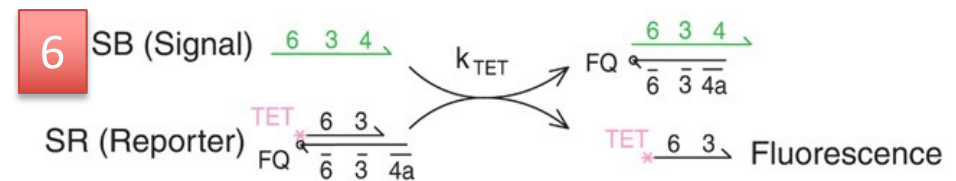
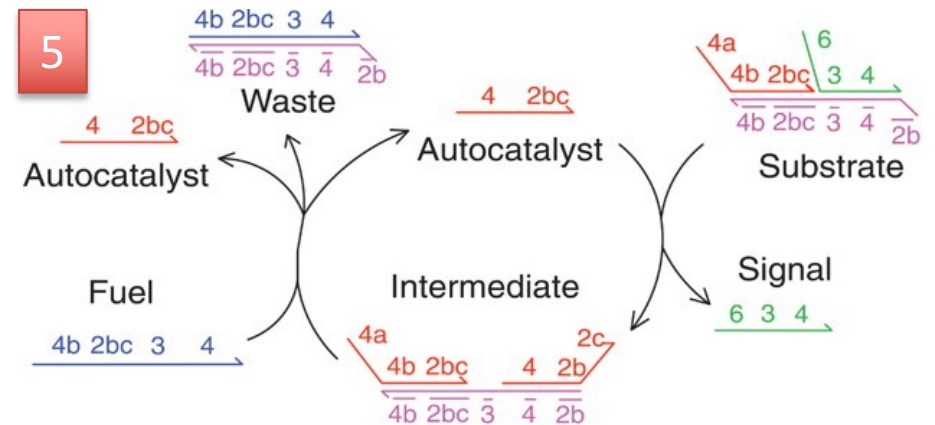
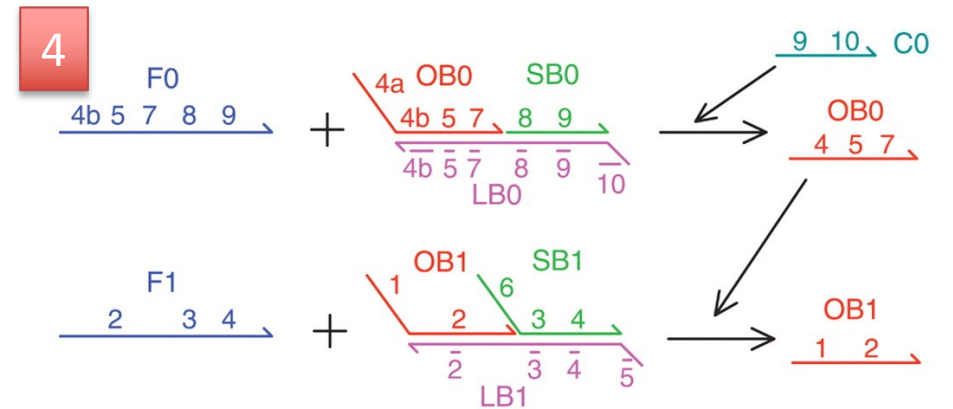
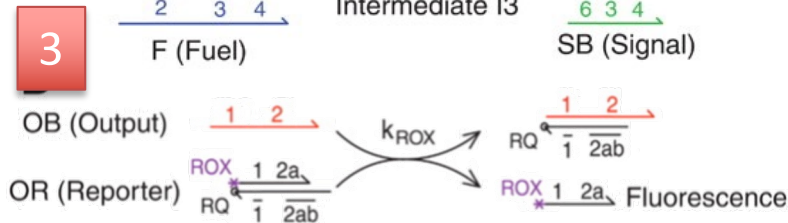
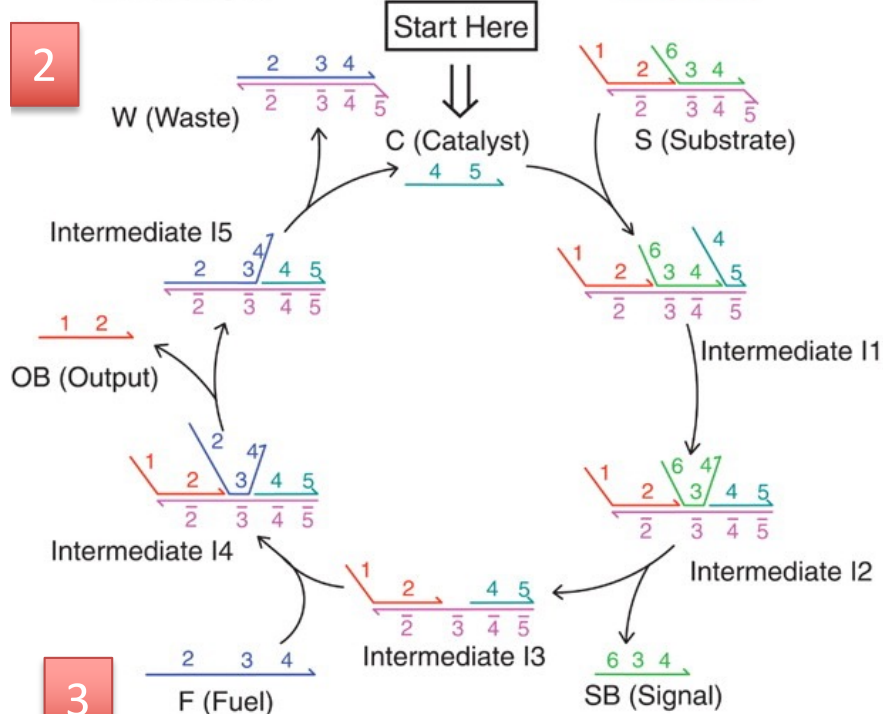

DNA Reaction Networks

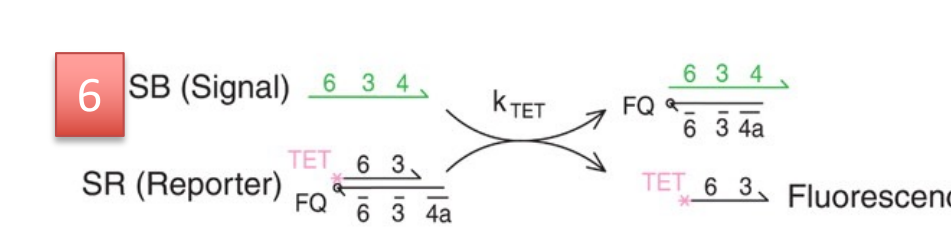
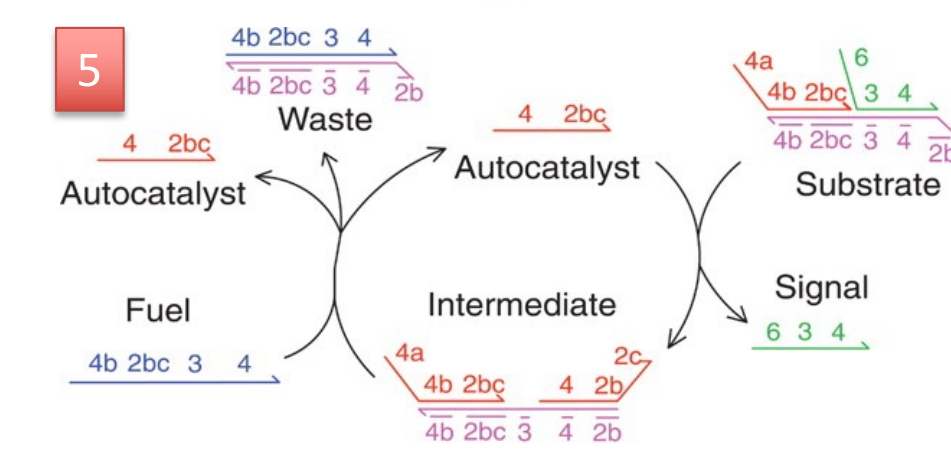
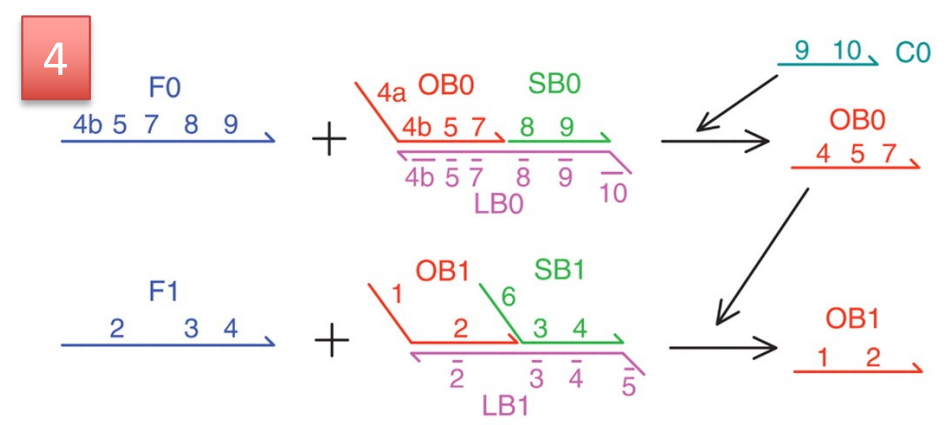
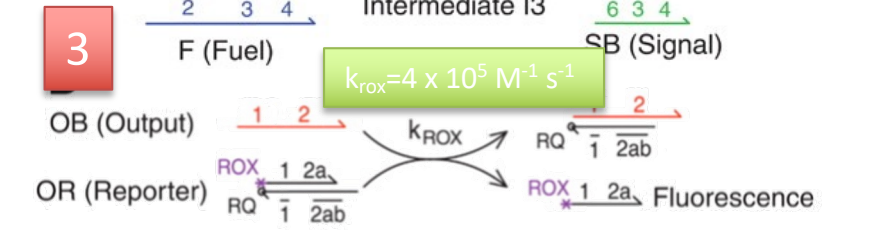
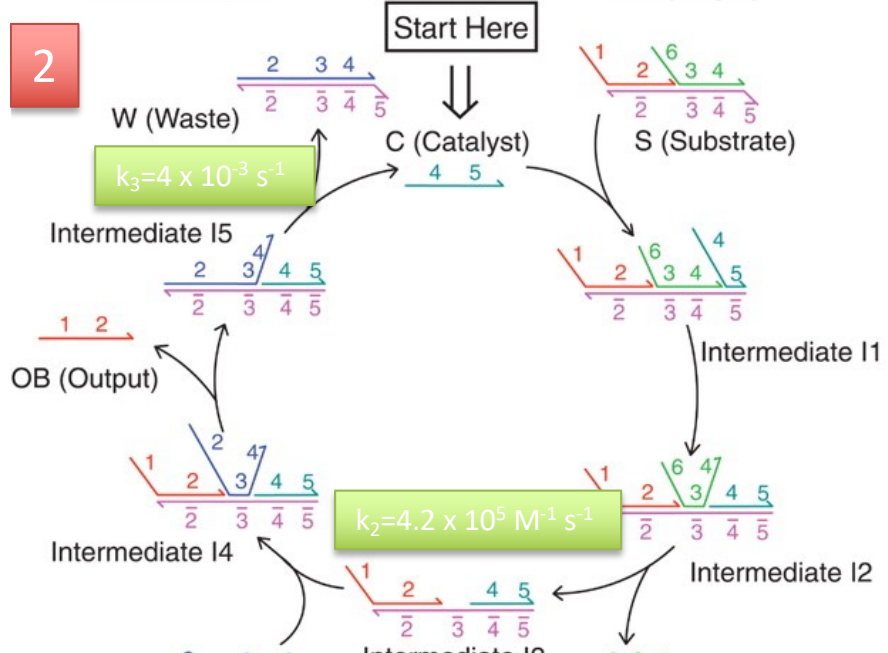
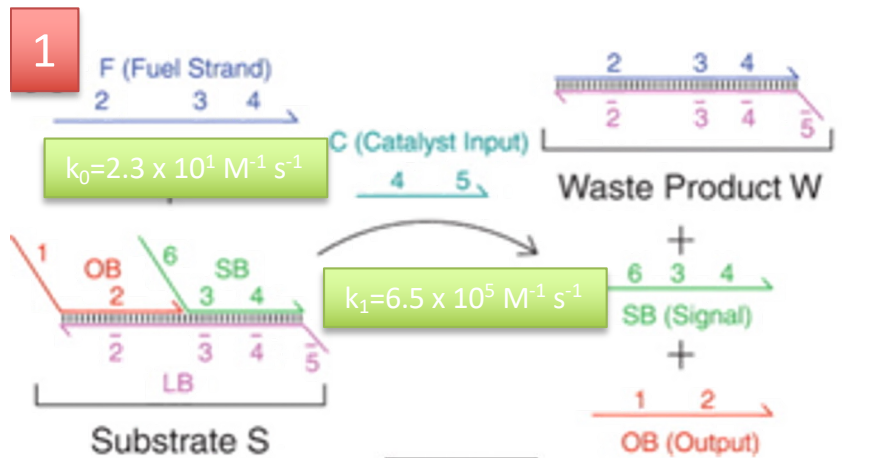

DNA Reaction Networks

Zhang et al Science 2007, 318 (16), 1121

Entropy-driven reactions:

(A) System components:

Number labels denote functional domains, which are continuous stretches of DNA that act as units in binding. Domain \bar{x} is the complement of (and will hybridize to) domain x .

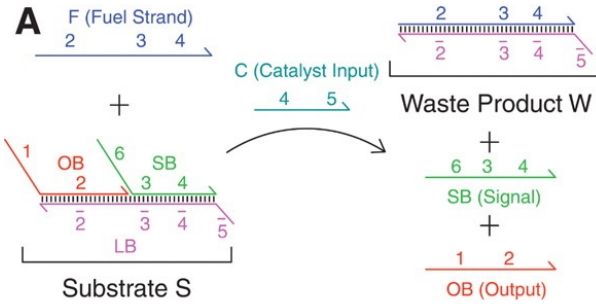

(B) The proposed catalytic pathway:

Reverse reactions are also present and modeled (with the exception of $I5+OB \rightarrow I4$, which occurs at a negligible rate).

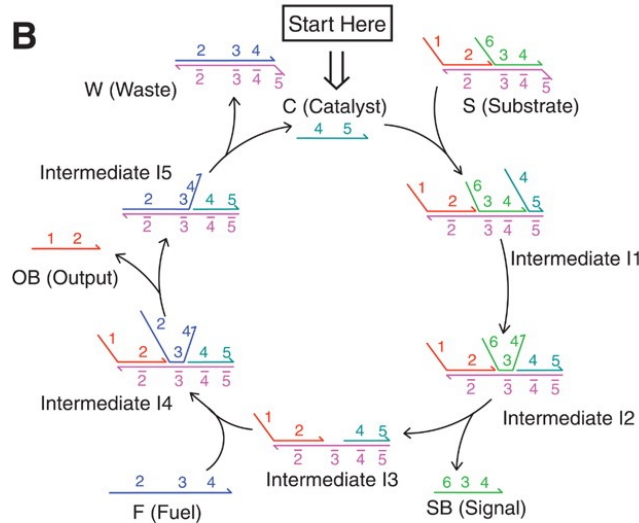

(C) Analysis by PAGE (12% native gel) of the reaction mechanism:

Here, $[S] = [F] = 200$ nM. $[C] = 200$ nM, except where C^* denotes 20 nM. "ann." denotes that species were annealed; "30 m" denotes that the reaction occurred for 30 min. See fig. S5 for the full gel, including control lanes.

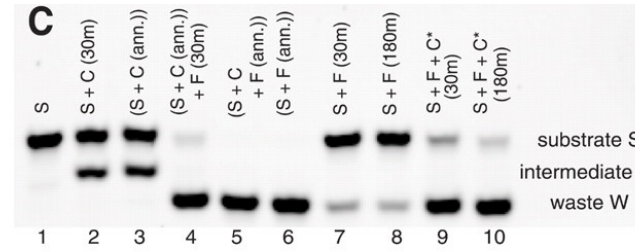

(D) Fluorescent reporter strategy.

ROX denotes the carboxy-X-rhodamine fluorophore, and RQ denotes the Iowa Black Red Quencher. Domain 2 is subdivided into 2a, 2b, and 2c; 2ab consists of 2a and 2b (Table 1).

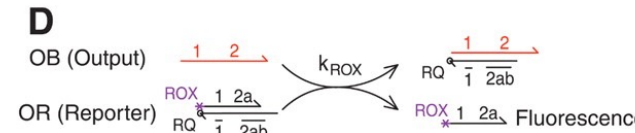

(E) Demonstration of catalysis.

Different amounts of C were introduced into the system at $t \approx 0$. Here, $[S] = 10$ nM = 1x, $[F] = 13$ nM, and $[OR] = 30$ nM. Fluorescence (in all figures) is reported in units such that 0.0 is the background fluorescence of the quenched reporter and 1.0 is the fluorescence of ~ 10 nM of triggered reporter. The control trace (black) shows the reaction with no substrate S and no catalyst C. Dotted lines show curves calculated with the reduced reaction model. sim, simulated.

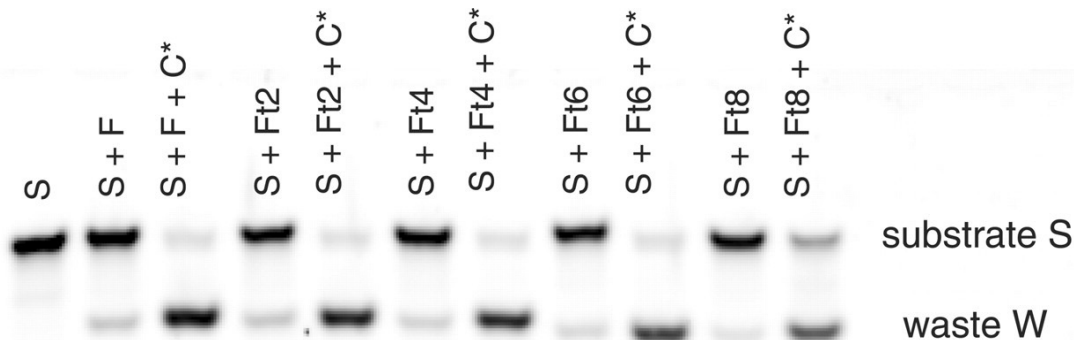
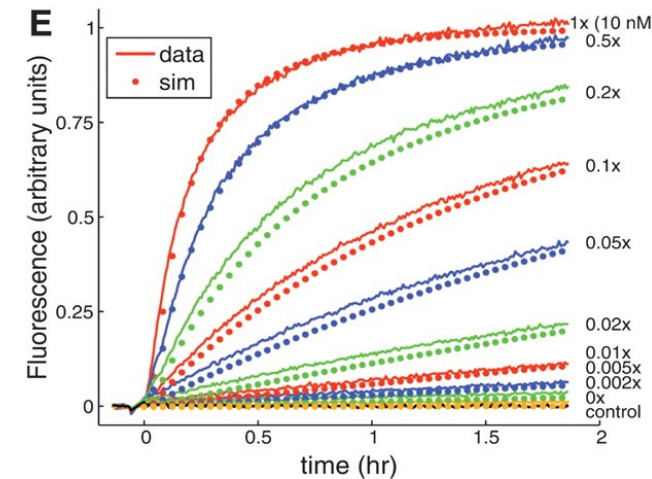

DNA Reaction Networks

Zhang et al Science 2007, 318 (16), 1121

A two-layer cascaded network:

(A) Schematic for design:

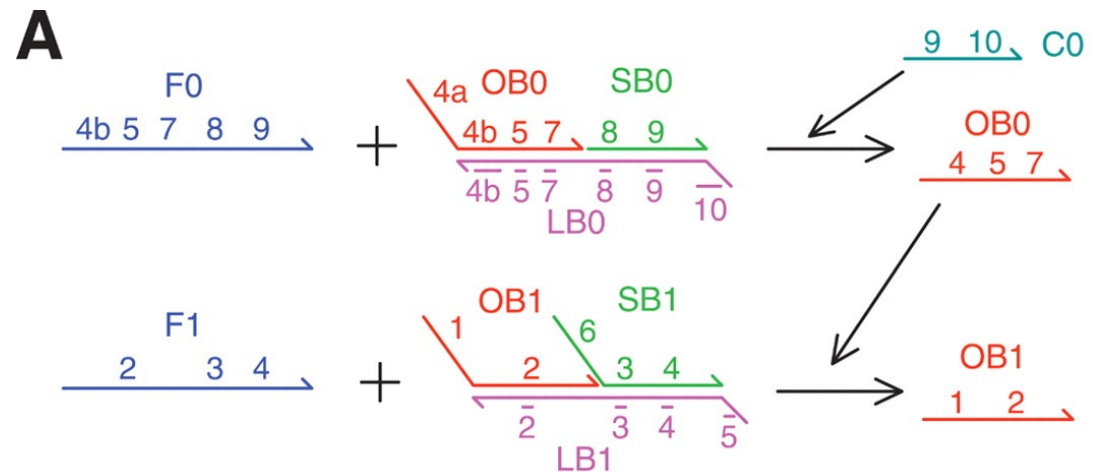

(B) Kinetics:

Indicated amounts of initial catalyst C0 were added at $t \approx 0$. Fluorescence derives from reporter complex OR (Fig. 1D) at 30 nM.

Dotted lines show simulated traces; see SOM text S8 for details on reaction rates and modeling. a.u., arbitrary units.

(Inset) Response to 0.0010x, 0.0003x, and 0.0001x catalyst:

The asterisk indicates that three independent reaction traces are shown. 1.0 fluorescence units correspond to ≈ 10 nM of triggered reporter.

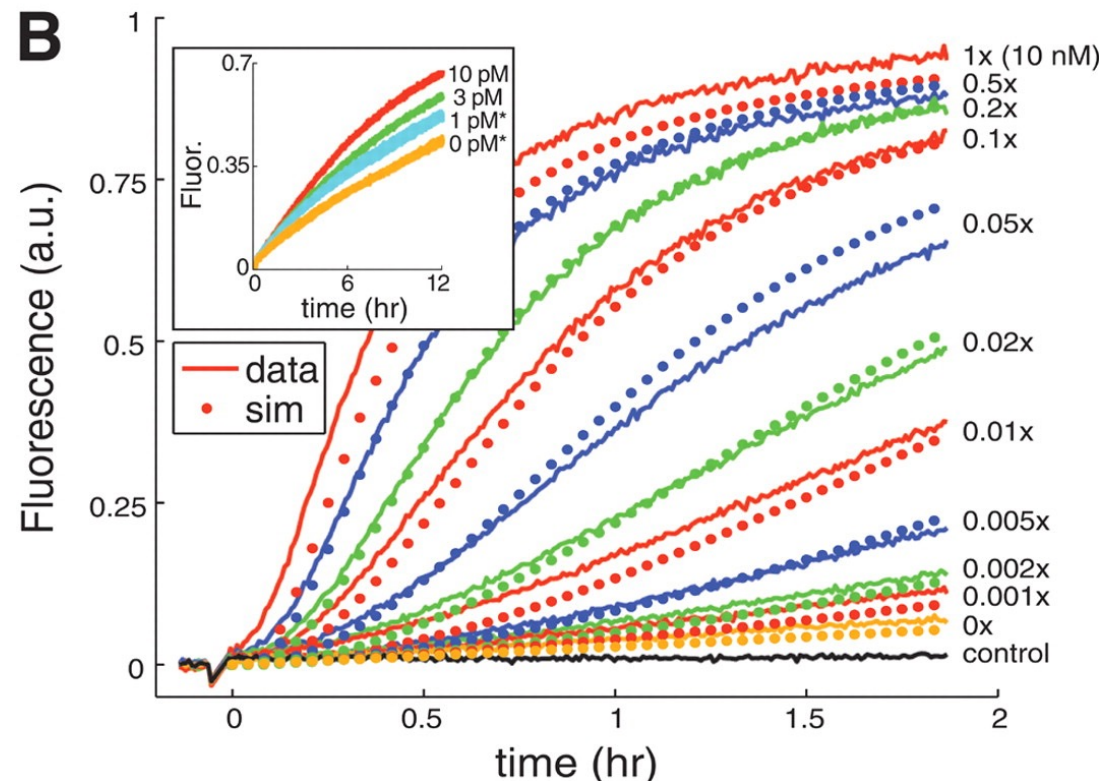

Autocatalytic Reaction:

A reaction where a product itself acts as a catalyst for the reaction.

- It can act as a catalyst for the same reaction or the coupled reaction.**
- It increases the rate of growth products of the reaction to be exponential.**

DNA Reaction Networks

Using an autocatalyst:

(A) Schematic for design:

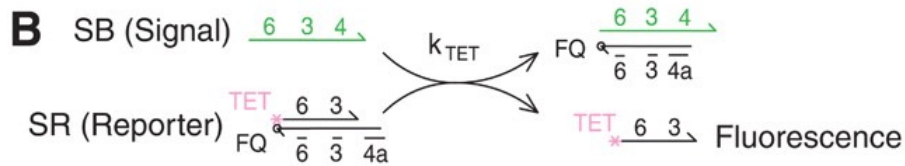
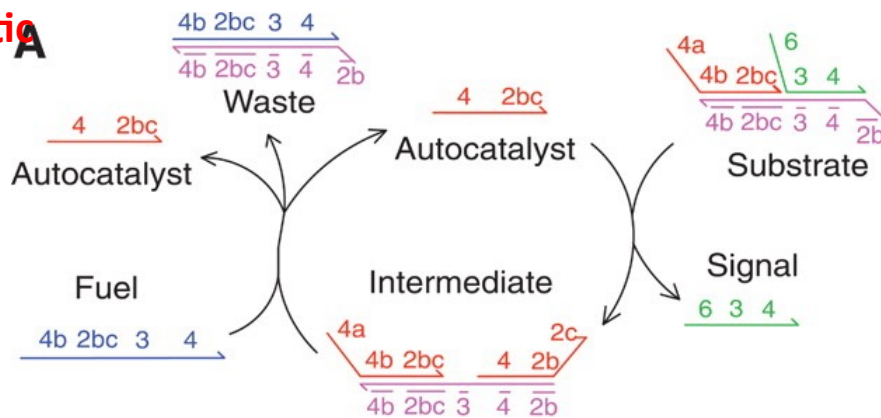

(B) Kinetics:

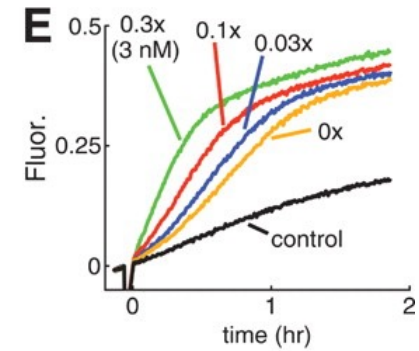
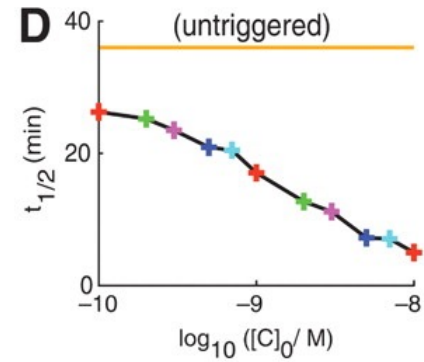
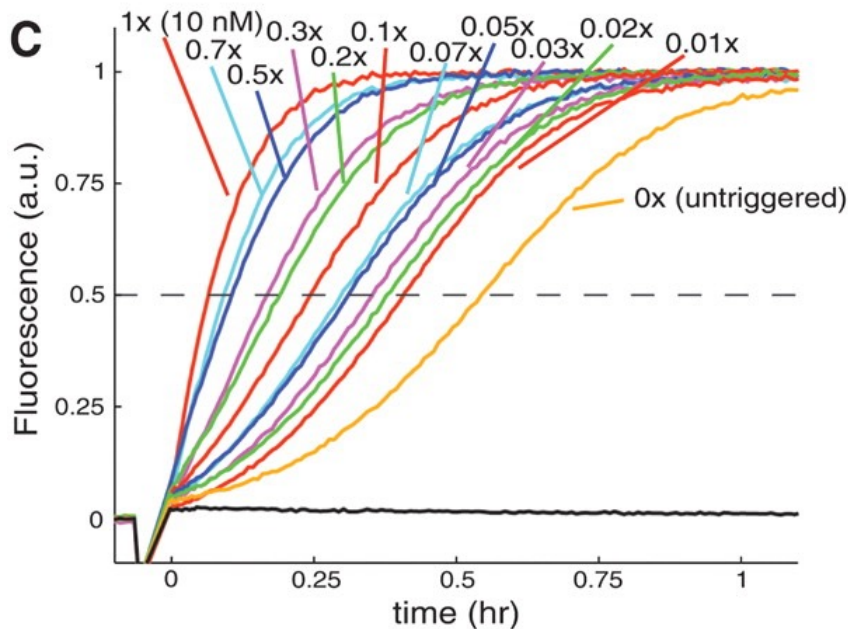

Allosteric:

The alteration of the activity of a protein through the binding of an effector molecule at a specific site.

Allosteric enzymes:

Enzymes that change their conformational ensemble upon binding of an effector, resulting in a change in binding affinity at a different ligand binding site.

This provides "action at a distance" through binding of one ligand affecting the binding of another at a distant site.

Allosteric Enzymes

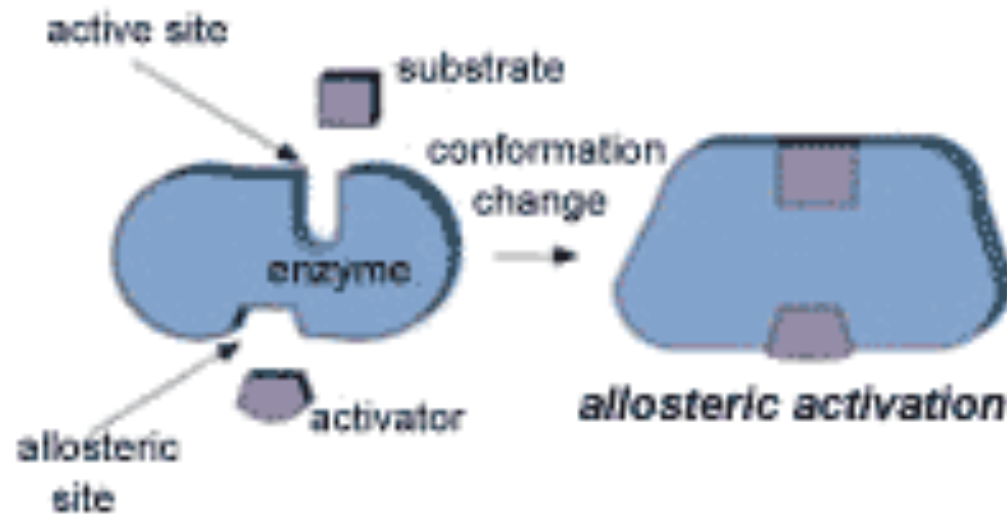
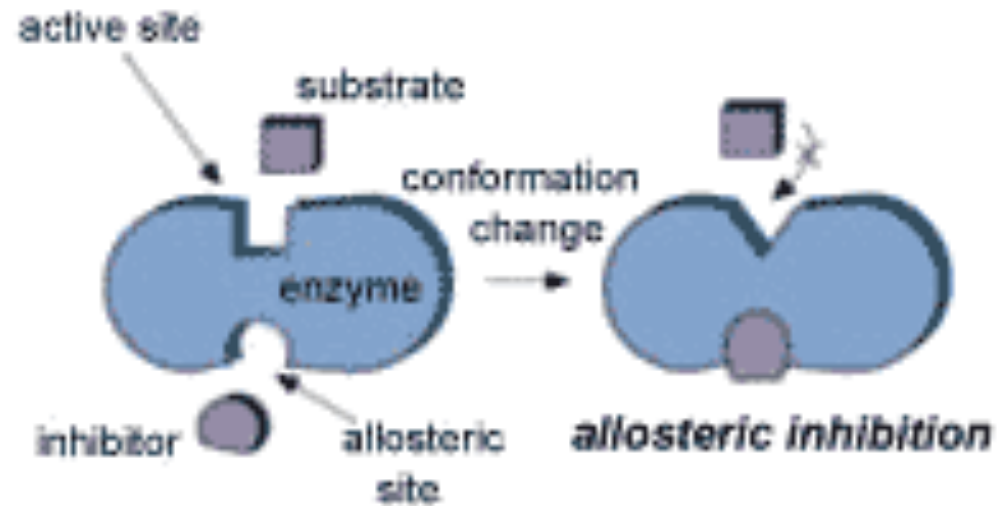

Allosteric DNA Catalytic Reactions

DNA gate design:

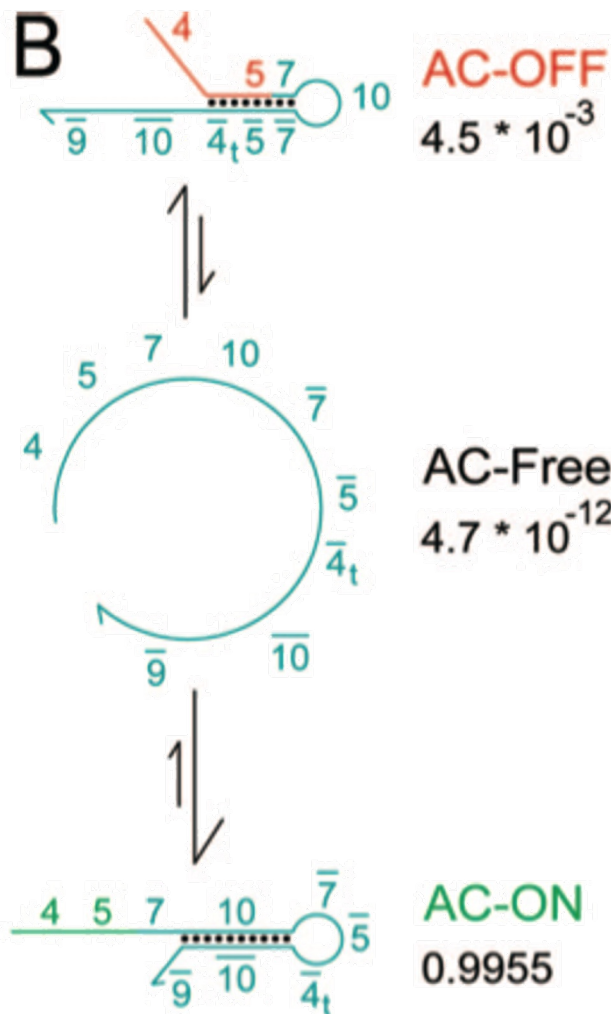

The Allosteric Catalytic Reaction:

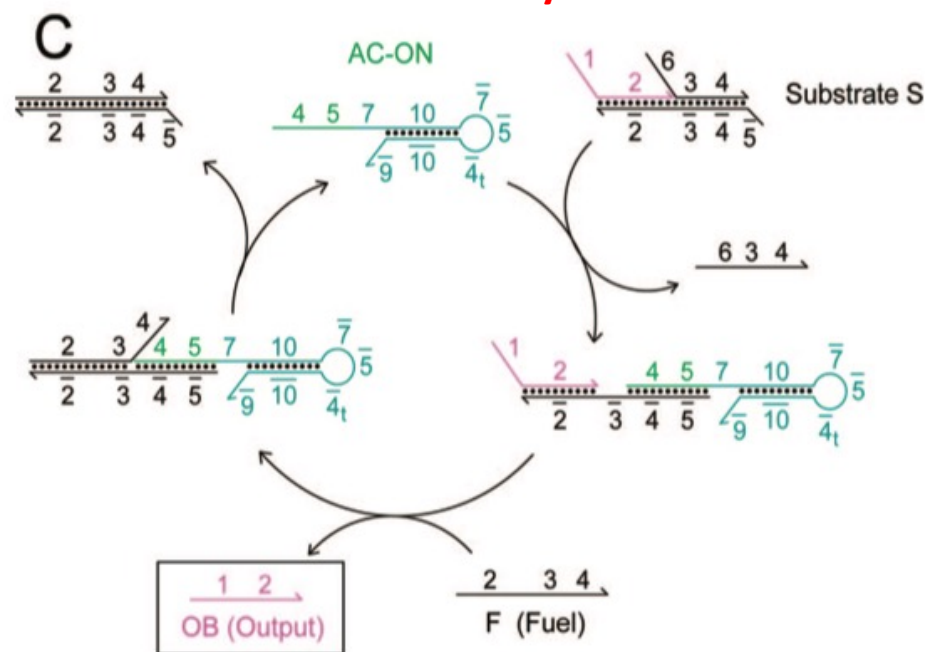

DNA Domain Sequences:

Table 1. Domain Sequences

domain	sequence	length (nt)
1	5'-CTTTCCTACA-3'	10
2a	5'-CCTACG-3'	6
2b	5'-TCTCCA-3'	6
2c	5'-ACTAACTTACGG-3'	12
3	5'-CCCT-3'	4
4	5'-CATTCAATACCTACG-3'	16
4t	5'-CG-3'	2
5	5'-TCTCCA-3'	6
6	5'-CCACATACATCATATT-3'	16
7	5'-TC-3'	2
8	5'-CTTGACTC-3'	8
9	5'-GTATCTAG-3'	8
10	5'-GTCTACTCCTAATG-3'	14

Figure 1. Allosteric DNA hybridization catalyst. (A) DNA abstraction. The double-helix DNA molecule (top) is typically abstracted as two directional lines, one for each strand, with base identities shown (middle). Here, we abstract the DNA molecule one step further by grouping contiguous nucleotides into domains, functional regions of DNA that act as a unit in binding (bottom). Domains are labeled by numbers. Domain \bar{x} is the complement of (and will hybridize to) domain x . The sequences of 11 and 12 are illustrative of the domain concept and not in use for the allosteric catalyst design. (B) The allosteric catalyst (AC). There are three mechanically important states that the AC can adopt: AC-OFF, AC-free, and AC-ON. Of these three, AC-ON is the most thermodynamically favored (due to the lengths of the hairpin stems; see Table 1), and AC-free is the least thermodynamically favored. The hairpin stem in AC-OFF is designed to be short enough that it can spontaneously open, causing AC to adopt the AC-free state. Then AC will quickly and with high probability fold into AC-ON. The predicted abundances of each state at equilibrium, for the sequences in Table 1, are shown.²⁶ Domain 4_t is a short two nucleotide domain that is complementary to the 3'-most two nucleotides of domain 4. The presence of domain 4_t helps ensure that the AC-OFF is catalytically inactive. (C) The catalytic cycle. The AC binds to the substrate S via domain 5 and displaces the strand $6 \cdot 3 \cdot 4$. The newly exposed $\bar{3}$ domain allows the fuel F to bind, displace output OB, and finally displace AC-ON. Domains 4 and 5 on the AC must be single-stranded in order for the catalytic cycle to proceed.

Allosteric DNA Catalytic Reactions

State changes by addition of inhibitor (Inh) and Activator (Act):

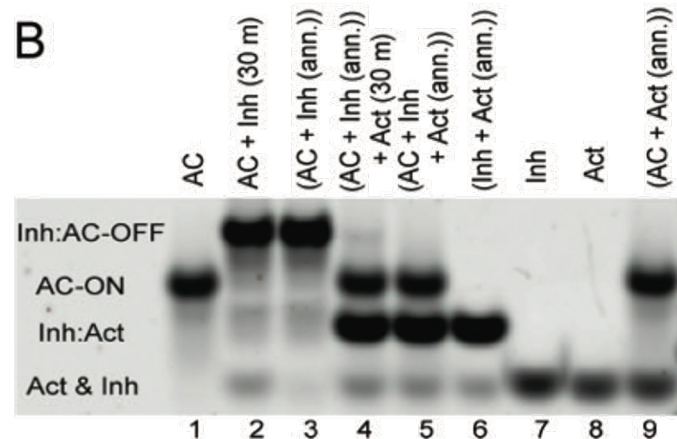
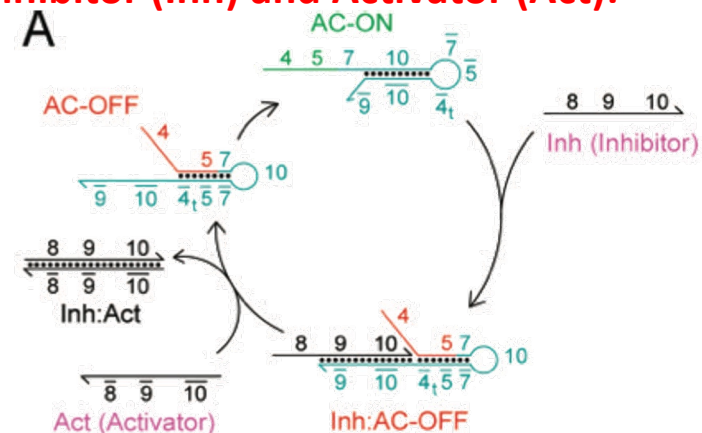

Fluorescence Reporting:

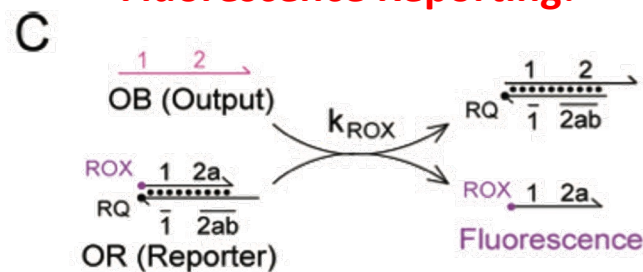

Fluorescence Increase over Time:

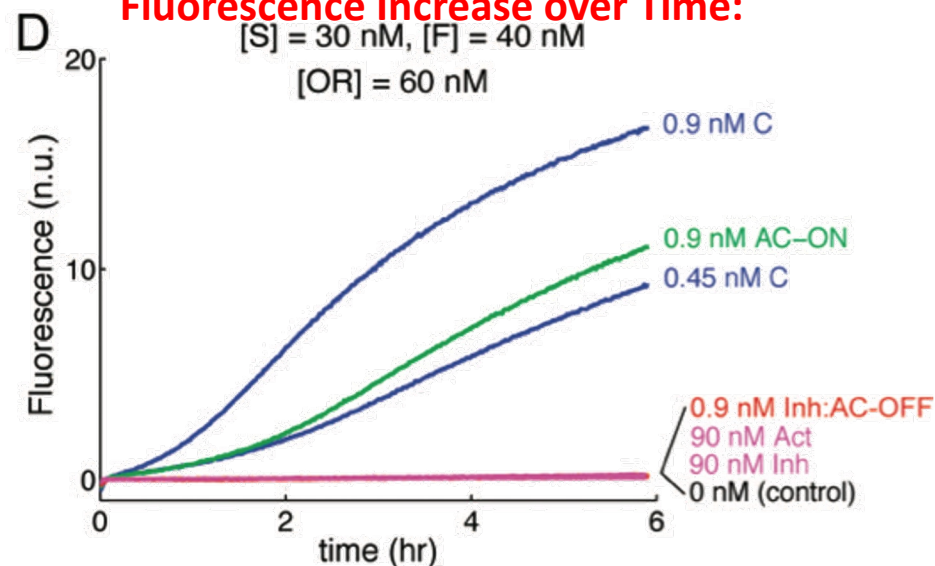
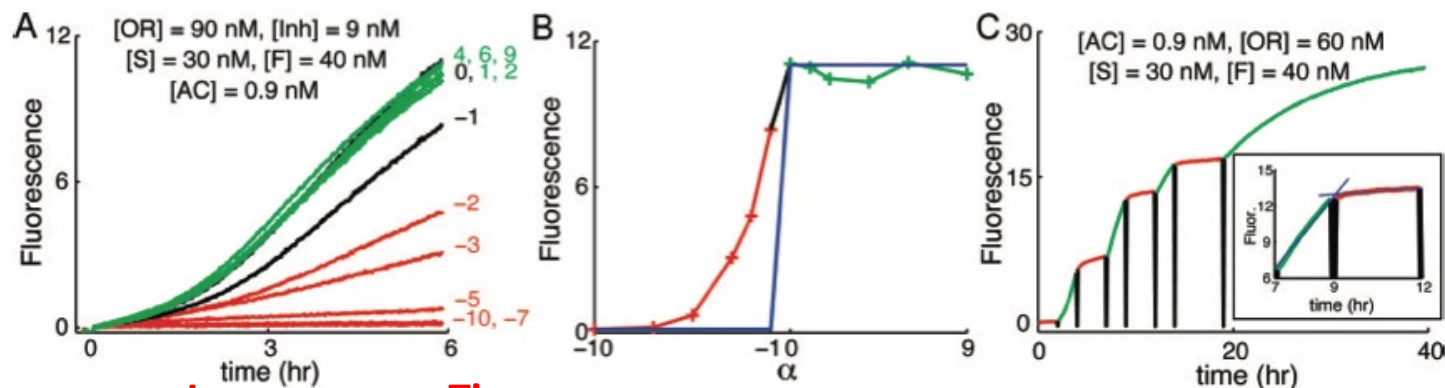

Figure 2. State changing of the AC. (A) State changing by addition of inhibitor (Inh) and activator (Act). Free Inh binds to AC-ON to form the Inh:AC-OFF complex. Free Act binds to Inh:AC-OFF to release AC-OFF and duplex waste product Inh:Act. AC-OFF then spontaneously converts to AC-ON. (B) Analysis by PAGE (12% native gel) of state changing. Here, $[AC] = 200 \text{ nM}$, $[Inh] = 250 \text{ nM}$, and $[Act] = 300 \text{ nM}$. “(ann.)” denotes that species were annealed; “(30 m)” denotes that the reaction proceeded for 30 min. Lanes 1 through 5 show slight smearing because the allosteric catalyst can dynamically switch between its two states over the course of the gel running. (C) The production of OB is quantitated via stoichiometric reaction with reporter complex OR to yield increased fluorescence. ROX denotes the carboxy-X-rhodamine fluorophore (attached to the DNA molecule via an NHS ester), and RQ denotes the Iowa Black Red Quencher. Domain 2 is subdivided into 2a, 2b, and 2c; 2ab consists of 2a and 2b (Table 1). The concentration of the OR reporter complex was always in excess of S to ensure that reporting delay time was approximately consistent. (D) Catalytic activity of the allosteric catalyst. Fluorescence (in all figures) is normalized so that 1 normalized unit (n.u.) of fluorescence corresponds to 1 nM of unquenched fluorophore-labeled strand 1•2a. Various reagents were added at $t \approx 0$. Serving as a control, catalyst C from ref 1 has sequence 4–5. Inh:AC-OFF was prepared by annealing AC with a 3× excess (2.7 nM final concentration) of Inh.

Allosteric DNA Catalytic Reactions

Allosteric Catalyst Behavior:



Fluorescence Increase over Time

Figure 3. Allosteric catalyst behavior. (A) Dependence of catalytic behavior on the balance of [Act] and [Inh]. [S] = 30 nM = 1x, [F] = 40 nM = 1.3x, [AC] = 0.9 nM, [Inh] = 9 nM. Various amounts of Act were added at $t = 0$ min, with the number label shown being the value of α , the stoichiometric excess of Act. Red shows where the AC is expected to be OFF (Inh:AC-OFF); green shows where AC is expected to be ON (AC-ON). (B) Sigmoidal activation curve. The total catalytic activity over 6 h (from (A)) is plotted against α . Blue trace denotes the expected behavior when AC, Inh, and Act are in equilibrium. (C) Dynamic switching. Initially, 0.9 nM AC is annealed with 2.7 nM Inh. Reagents were added to cause concentration changes as follows: 20 nM Act at $t = 2$ h, 40 nM Inh at $t = 4$ h, 60 nM Act at $t = 7$ h, 80 nM Inh at $t = 9$ h, 100 nM Act at $t = 12$ h, 120 nM Inh at $t = 14$ h, 140 nM Act at $t = 19$ h. The fluorescence level was adjusted for dilution by multiplying by the dilution factor where appropriate. (C, inset) Rate fitting for observed activity between 7 and 12 h. The production rate of OB was fit to be 3:0 nM/h for AC-ON, and 0:18 nM/h for Inh:AC-OFF (blue traces).

Table 2. Strand Sequences

strand	domains	sequence
AC	4 5 7 10 7 5 4t 10 9	CATTCAATACCCTACG TCTCCA TC GTCTACTCCTAATG GA TGGAGA CG CATTAGGAGTAGAC CTAGATAC CTTGACTC GTATCTAG GTCTACTCCTAATG
Inh	8 9 10	CATTAGGAGTAGAC CTAGATAC GAGTCAAG
Act	10 9 8	CCTACGCTCCAACCTAACTTACGG CCCT
F	2 3 4	CATTCAATACCCTACG
OB	1 2	CTTTCCTACA CCTACGCTCCAACCTAACTTACGG
SB (part of S)	6 3 4	CCACATACATCATATT CCCT CATTCAATACCCTACG
LB (part of S)	5 4 3 2	TGGAGA CGTAGGGTATTGAATG AGGG CCGTAAGTTAGTTGGAGACGTAGG
OF (part of OR)	1 2a	CTTTCCTACA CCTACG
OQ (part of OR)	2b 2a 1	TGGAGA CGTAGG TGTAGGAAAAG

Table 3. Catalytic Activity Based on State

time (h)	state	OB production rate (nM/h)
0–2	OFF	0.00
2–4	ON	3.5
4–7	OFF	0.24
7–9	ON	3.0
9–12	OFF	0.18
12–14	ON	1.6
14–19	OFF	0.08

Allosteric DNA Catalytic Reactions

The Allosteric Catalytic Reaction:

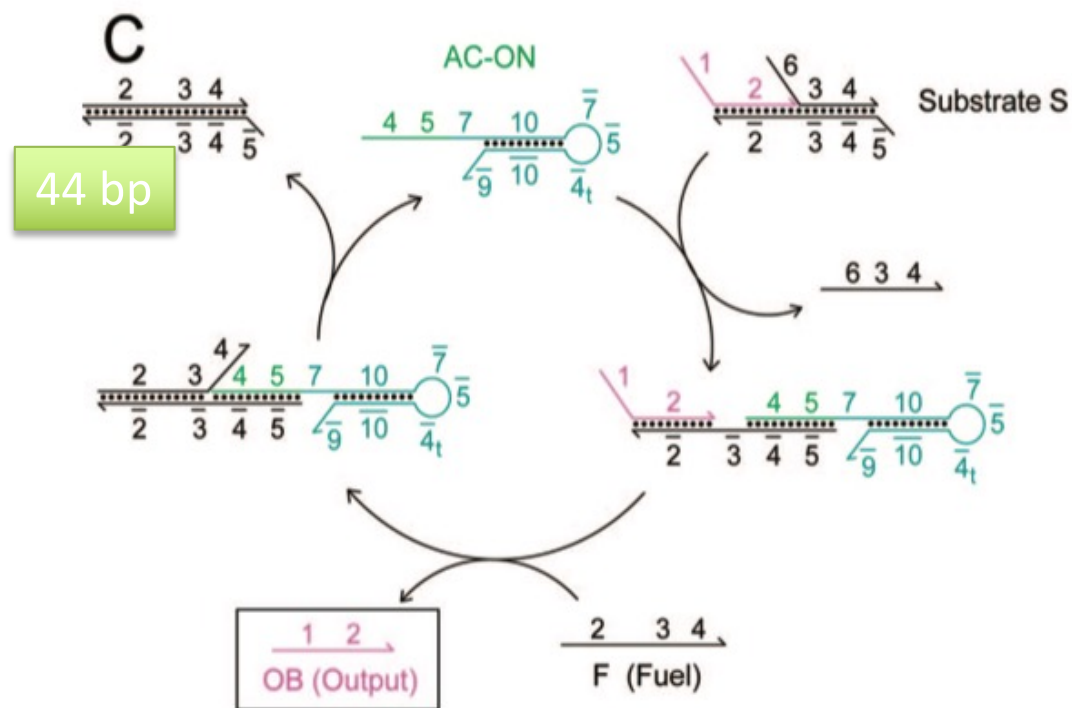
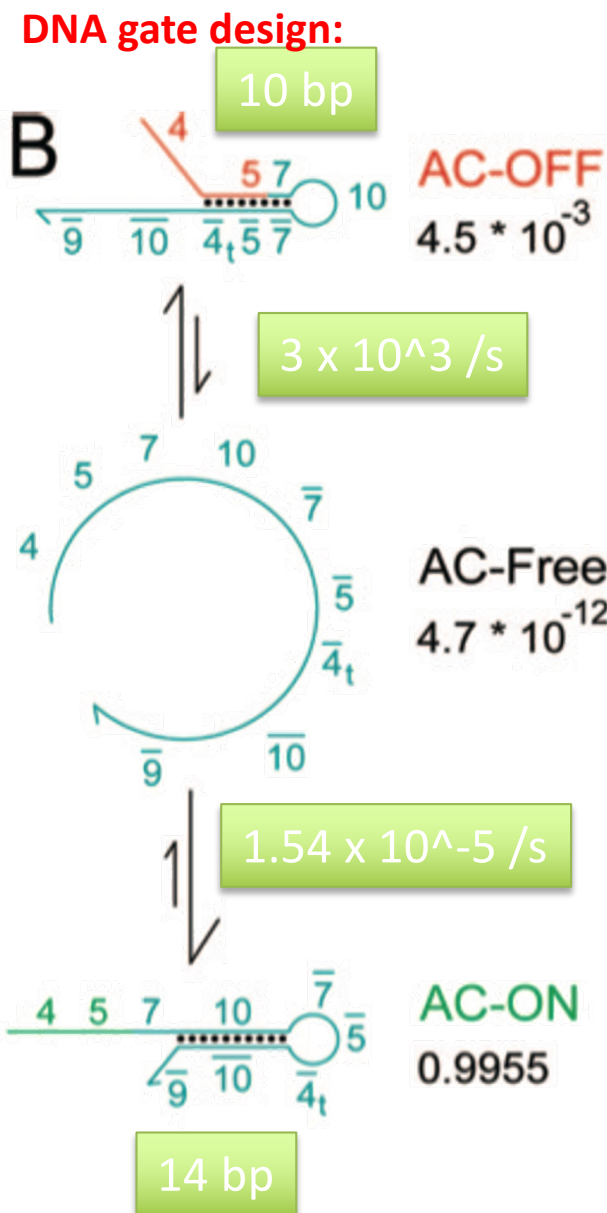

Fluorescence Reporting:

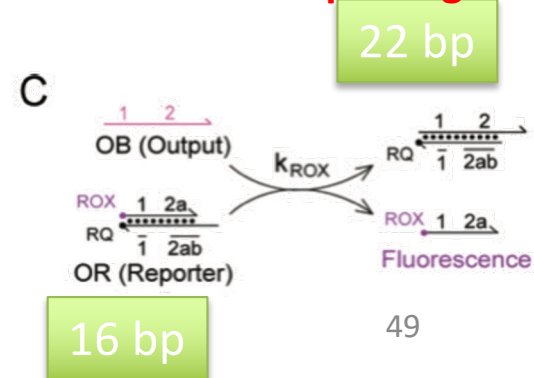

Allosteric DNA Catalytic Reactions

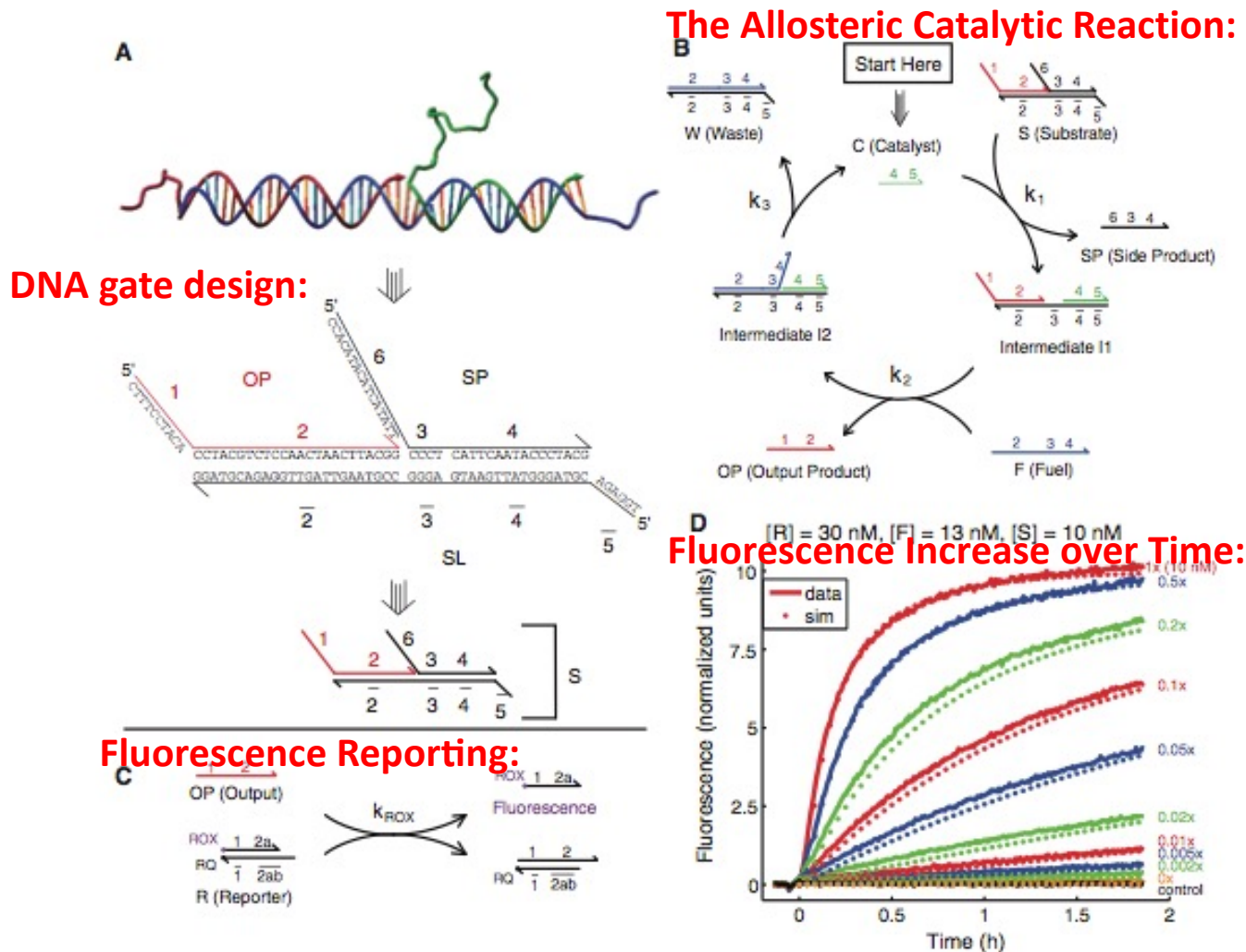

Table 1. Domain sequences

Dom.	Sequence	Length (nt)
1	5'-CITTCTCTACA-3'	10
2a	5'-CCTACG-3'	6
2b	5'-TCTCCA-3'	6
2c	5'-ACTAACITTCAGG-3'	12
2	5'-CCTACGTCCTCAACTAACITTCAGG-3'	24
3	5'-CCCT-3'	4
4	5'-CATTCAATACCCTACG-3'	16
5	5'-TCTCCA-3'	6
6	5'-CCACATACATCATATT-3'	16
7	5'-TTCACCTCAGTTATG-3'	15
8	5'-TCAATTCCTAACATA-3'	15
9	5'-TTTTTTTTTTTTTA-3'	15
10	5'-CACACA-3'	6
11	5'-ACTTCAGTCATTAAGC-3'	16
12	5'-AGAC-3'	4
13	5'-CCATACAAGTATCA-3'	14

Sequences for domains 1-6 are from (9).

Figure 1. A non-covalent strand displacement reaction catalyzed a target ssDNA molecule *C* [adapted from (9)]. (A) DNA abstraction. The double-helix DNA molecule (top) is typically abstracted as two directional lines, one for each strand, with base identities shown (middle). Here, we abstract the DNA molecule one step further by grouping contiguous nucleotides into domains, functional regions of DNA that act as a unit in binding (bottom). Domains are labeled by numbers. Domain \bar{x} is the complement of (and will hybridize to) domain x . The strands *OP*, *SP* and *SL* form the three-stranded DNA complex *S*. The DNA molecule in the top panel was drawn using Nanoengineer, a free DNA visualization software by Nanorex. (B) The designed mechanism of catalytic function. (C) Fluorescent reporter complex. Output product *OP* reacts stoichiometrically with reporter complex *R* to yield a fluorescent strand. ROX denotes the carboxy-X-rhodamine fluorophore (attached to the DNA molecule via an NHS ester), and RQ denotes the Iowa Black Red Quencher. This indirect reporter complex was used because of the thermodynamic effects of fluorophore-quencher binding (20). From (9), k_{ROX} , the second-order rate constant of reaction between *OP* and *R*, was measured to be $4 \times 10^5 \text{ M}^{-1} \text{ s}^{-1}$. In experiments, the concentration of the reporter *R* was in excess of the concentration of the fuel *F* and substrate *S* to minimize the reporter delay (no more than 2 min for $[R] = 30 \text{ nM}$). (D) Experimental and simulation results from (9). Dotted lines show ordinary differential equation (ODE) simulation results according to the model in Table 2.

Allosteric DNA Catalytic Reactions

Fluorescence Increase over Time:

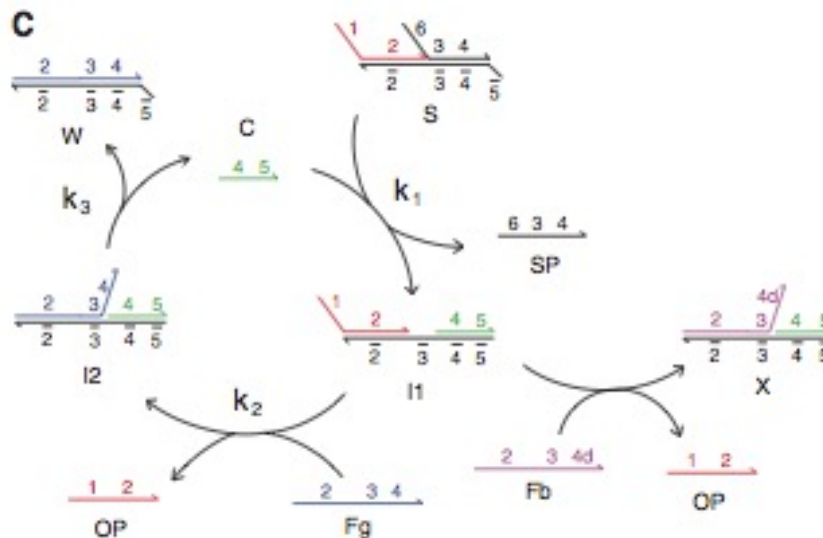
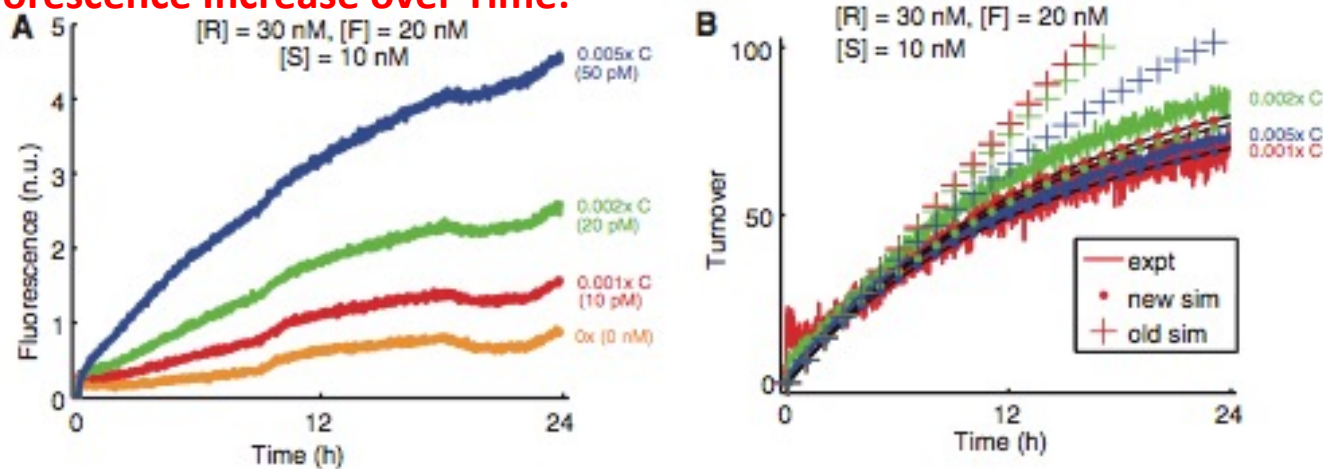

Table 2. Original model

$S + C \xrightleftharpoons[k_2]{k_1} I1 + SP$	$K_1 = 6.5 \times 10^5 \text{ M}^{-1} \text{ s}^{-1}$
$I1 + F \xrightarrow{k_2} I2 + OP$	$K_2 = 4.2 \times 10^5 \text{ M}^{-1} \text{ s}^{-1}$
$I2 \xrightleftharpoons[k_1]{k_3} W + C$	$K_3 = 4 \times 10^{-3} \text{ s}^{-1}$
$S + F \xrightarrow{k_0} OP + SP + W$	$K_0 = 2.3 \times 10^1 \text{ M}^{-1} \text{ s}^{-1}$

Table 3. Revised model

$S + C \xrightleftharpoons[k_2]{k_1} I1 + SP$	$k_1 = 2.7 \pm 0.5 \times 10^5 \text{ M}^{-1} \text{ s}^{-1}$
$I1 + Fg \xrightarrow{k_2} I2 + OP$	$k_2 = 1.1 \pm 0.7 \times 10^6 \text{ M}^{-1} \text{ s}^{-1}$
$I2 \xrightleftharpoons[k_1]{k_3} W + C$	$k_3 = 1.1 \pm 0.5 \times 10^{-2} \text{ s}^{-1}$
$S + Fg \xrightarrow{k_0} OP + SP + W$	$k_0 = 5 \text{ M}^{-1} \text{ s}^{-1}$
$I1 + Fb \xrightarrow{k_2} X + OP$	
$S + Fb \xrightarrow{k_0} OP + SP + W2$	$\chi = \frac{[Fb]}{[Fg] + [Fb]} = 1.0 \pm 0.3 \times 10^{-2}$
$C + W2 \xrightarrow{k_1} X$	

Figure 2. Catalytic turnover. (A) Raw data for turnover experiments. Traces showed significantly more noise than typical; possibly, this is due to lamp and temperature instability. (B) Turnover plotted as a function of time. Turnover is calculated as the excess normalized fluorescence above leak ($0 \times$ trace) divided by concentration of catalyst; e.g. $T_{0.001x}(t) = (F_{0.001x}(t) - F_{0x}(t))/0.001 \cdot 10 \text{ nM}$. 'Old sim' denotes simulations using the model presented in (9), which was fitted only to the 10 nM data shown in Figure 1D. The 'new sim' simulations use the model and rate constants fitted to the data presented in this article. The relative ordering and the quantitative differences between the 'new sim' simulations and the experimental results are not considered significant—all traces are considered to be within experimental error of one another. (C) Our new model that accounts for F subpopulations. A small fraction (fitted to be 1.0%) of F exists as Fb , with deletions in domain 4. These react with $I1$ to yield X , from which C cannot dissociate.

Allosteric DNA Catalytic Reactions

Fluorescence Increase over Time at various Substrate S Concentrations:

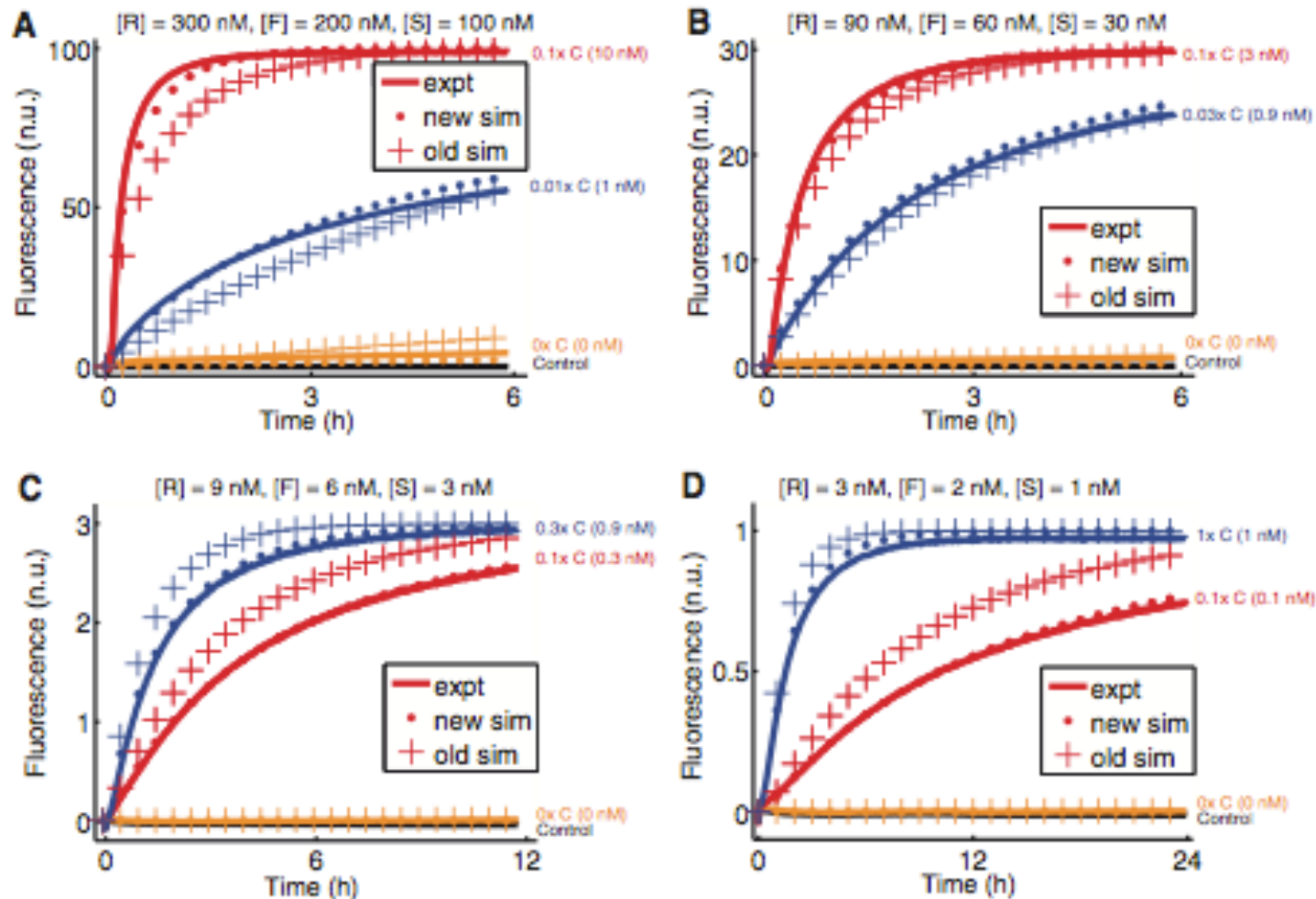

Figure 3. Catalytic function and model results for (A) 100 nM, (B) 30 nM, (C) 10 nM and (D) 1 nM substrate S concentration. The new model that accounts for catalyst inactivation (Table 3) fits the experimental data better than the old model (Table 2). Red traces denote 0.1 \times catalyst, whereas blue traces denote catalyst concentrations of \sim 1 nM.